



MARINE



ENERGY. ANYTIME. ANYWHERE.

Energy. Anytime. Anywhere.



INDEX

Introduction	4
Application examples	5
Sailing yacht Ecolution	6
Motor yacht Nordhavn 68	10
The green miles	14
Systems	18
Accessories	22
Technical information	25
About Victron Energy	102



INTRODUCTION

Marine market

Whether you sail for fun or on a professional basis, it is of the utmost importance to have a reliable power supply for all the electrical equipment to properly function, even in the middle of the sea. Victron Energy offers a broad range of products that are extremely suitable for your onboard power system.

We proudly present you our modern translation for freedom and independence.



Energy. Anytime. Anywhere.



APPLICATION EXAMPLES

Our products are being used in many different kinds of vessels: sailing yachts, cruise ships, sloops, tugboats, motor boats and container ships. To give you an idea of the possibilities of the use of our products, we gathered a few application examples.

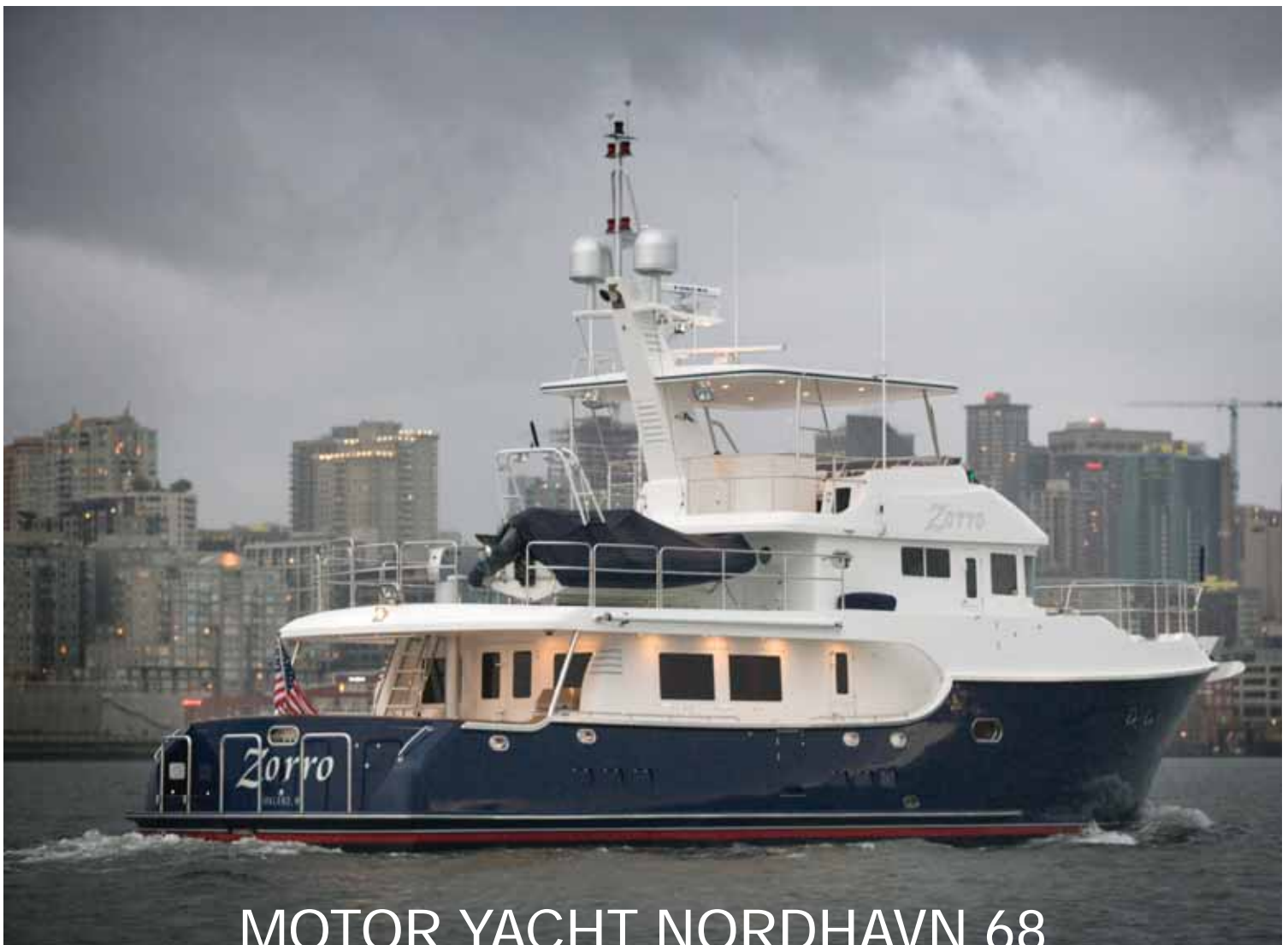
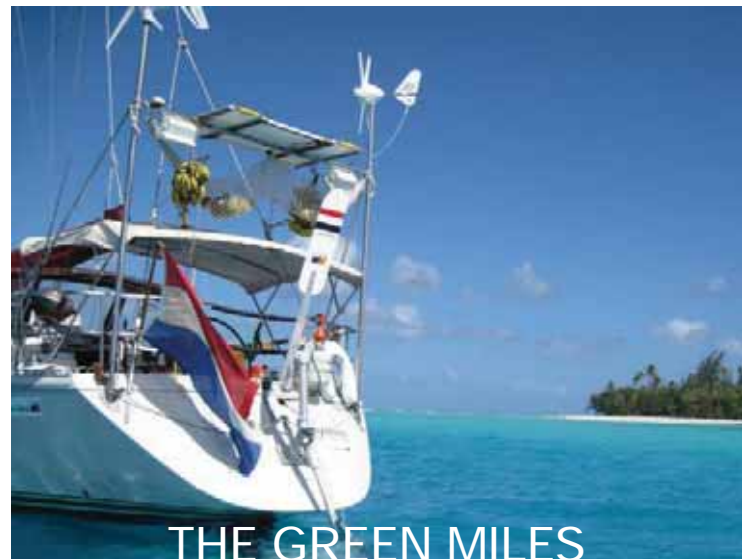

SAILING YACHT ECOLUTION

The Netherlands: Ecolutions B.V.

Generating energy from water, wind and sun

The Ecolution is a 85.3 feet (26 meter) long sailing yacht equipped with many sustainable techniques. It is designed by Wubbo Ockels, a Dutch physicist and a former astronaut (first Dutch citizen in space, 1985). During sailing the yacht develops substantial power, of which a part can be tapped without imposing significant reduction of sailing qualities. Two propellers are placed between the rudders of the vessel not only for propulsion but also for generating energy. The use of solar energy on the yacht is still in development.

Robust back-up system from Victron Energy

A safe and smart battery system has been designed by Victron specialist Johannes Boonstra. The energy generated by the Ecolution will be stored in 120 Victron batteries. With a total weight of 10.000 kg, the batteries will replace the use of conventional lead-ballast. The batteries are connected to a 24V Centaur charger and several Quattro inverters/chargers from Victron Energy. Wubbo Ockels is very happy with the system: 'It is a great back-up system, even when the central system fails there will still be an extra back-up'.

Victron equipment

Quattro inverter/chargers 10kVA
Isolation transformer 3600W
24V Centaur charger
120 x Victron batteries





SAILING YACHT ECOLUTION



SAILING YACHT ECOLUTION

System schematic

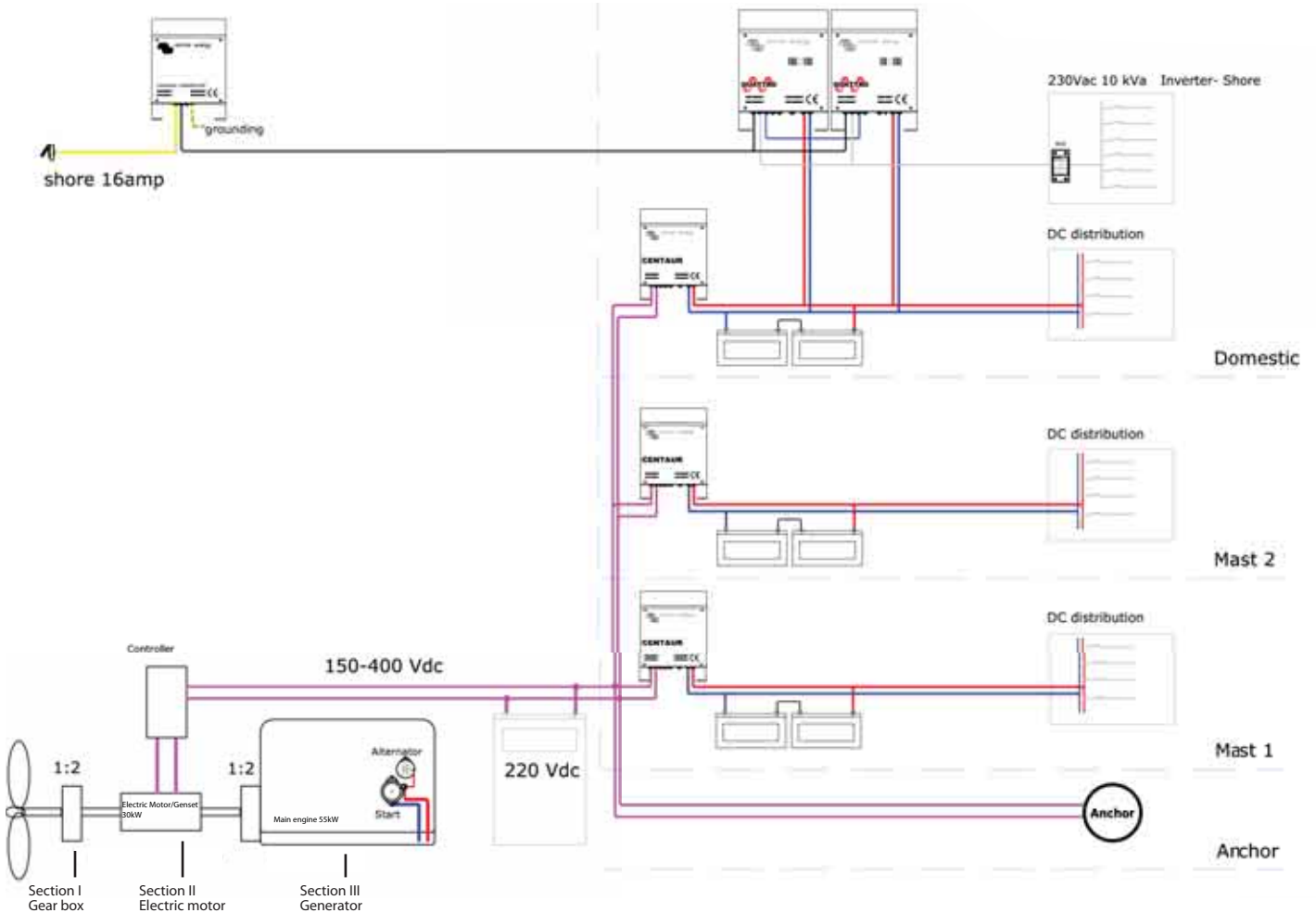

The drive system is highly redundant and consists of two identical "strings" of a mechanically coupled (bio) Yanmar diesel engine (55kW), a 20kW electrical motor/generator, a gearbox and a 'camber-adaptive' propeller. The sections I, II and III can be detached by couplings. Electrical power generation and electrical propulsion is provided by section I and II, while III and II provides a backup diesel generator function. Section I and III provides direct diesel propulsion.



MOTOR YACHT NORDHAVN 68

US, California: Pacific Asian Enterprises/Nordhavn Yachts

This 68 feet (20.73 meters) motor yacht is the forward pilothouse model of the Nordhavn 68 series. Everything you need for a comfortable stay is on board of this yacht: a large saloon, an outdoor living space, a galley, a laundry room, a master cabin and guest cabins. The rooms on board of the Nordhavn 68 series are finished in teak.

Appliances

The yacht is modernly decorated and equipped with a long list of comfort and convenience features: the galley is fully equipped with first-rate appliances, including a Sub-Zero side-by-side refrigerator/freezer and GE cook top and stainless steel convection wall oven. In the living area and in the cabins are large plasma TVs installed.

Victron equipment

3 x Quattro 24/5000/120-50/30
Digital Multi Control Panel

Specifications:

LOA: 68' / 20.73 M
LWL: 63' 2' / 19.25 M
BEAM: 20' 4" / 6.2 M
DRAFT: 6' 10" / 2.08 M
DISPLACEMENT: 190,000 lbs / 86.10 MT
HP: 425 hp @ 1,900 rpm

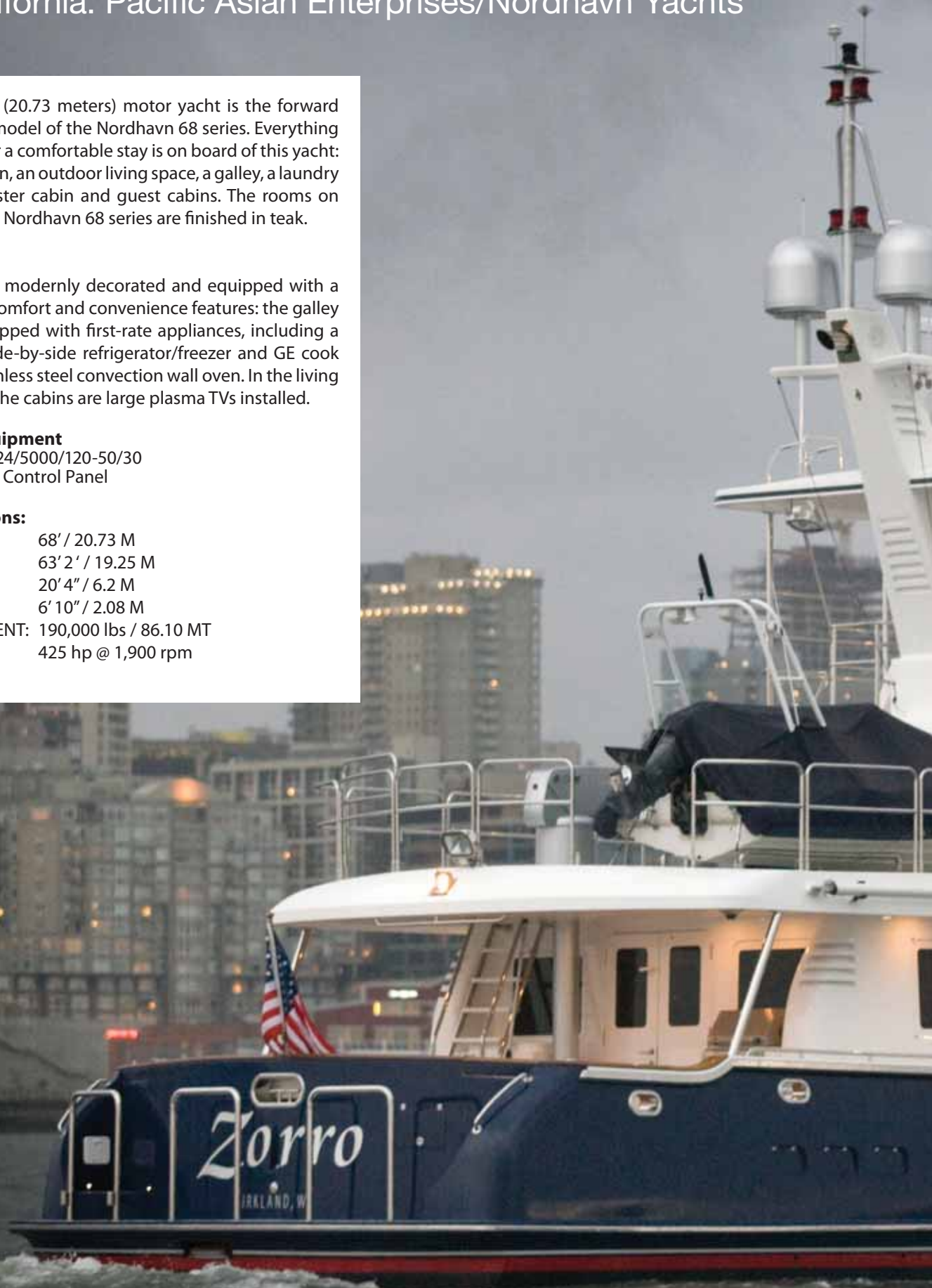



Nordhavn 68 'Zorro' - Seattle, Washington. Photo: Stephen Cridland

MOTOR YACHT NORDHAVN 68



Photo: Stephen Cridland



Photo: Stephen Cridland

MOTOR YACHT NORDHAVN 68

System schematic

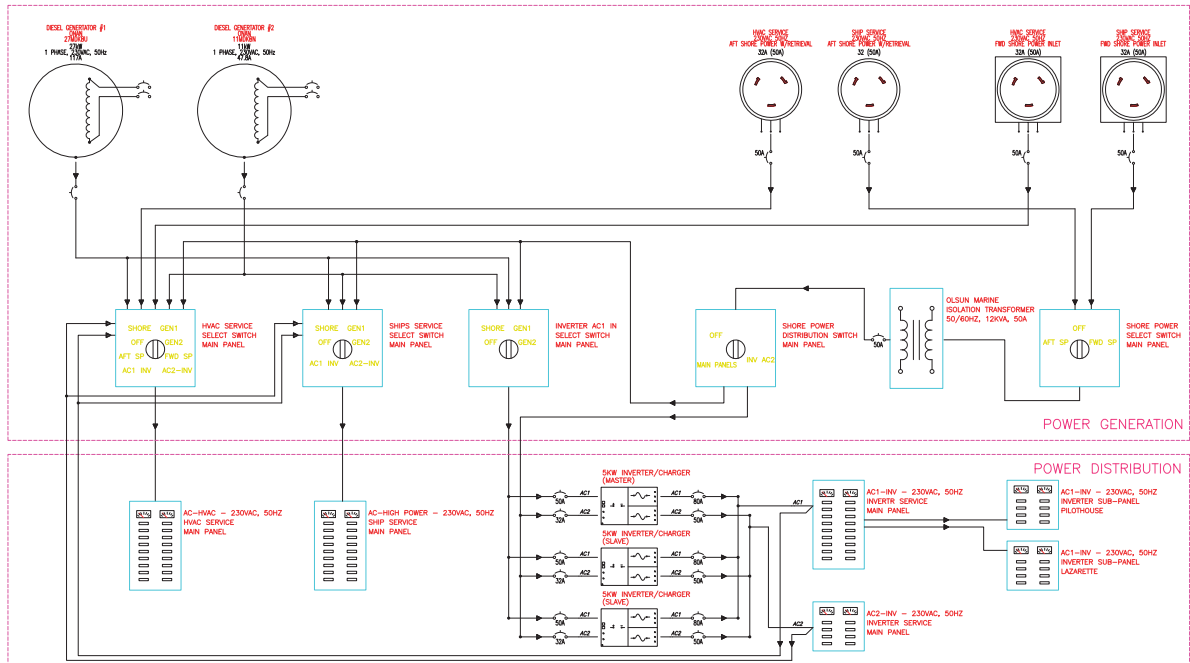

Photo: Stephen Cridland

THE GREEN MILES

The Netherlands: green project for blue oceans

The Green Miles is a project in which Arjen van Eijk and Florian Dirkse sailed around the world in two years (2010 - 2012), raising awareness on ocean climate. They sailed 50.000 kilometers, visiting 26 countries.

The Green Miles project was started to create awareness among the general public for the problems of our oceans. In addition, Arjen and Florian wanted to inspire people to interact with the world and the oceans in a green way.

Green sailing

The Green Miles' sustainable use of windpower to sail the world means there will be minimal use of fossil fuels and almost zero emissions. The yacht has also been adapted in several key areas. There are a few solar panels on board. A wind turbine provides additional energy. A waste disposal system means no harmful refuse needs to be thrown overboard. Green waste will be pulped so that sea creatures are able to feed on it. The boat has been fitted with a saltwater pump to prevent waste of drinking water, and energy-saving LED-lighting has been installed. The motor will only be used sparingly.

Victron equipment

Phoenix Charger 12/50
Phoenix Multi Control Panel
Phoenix Inverter 12/1200
Cyrix-i
2 x 150Ah AGM Batteries



THE GREEN MILES

Independent energy supply by Victron Energy.

THE GREEN MILES

System schematic

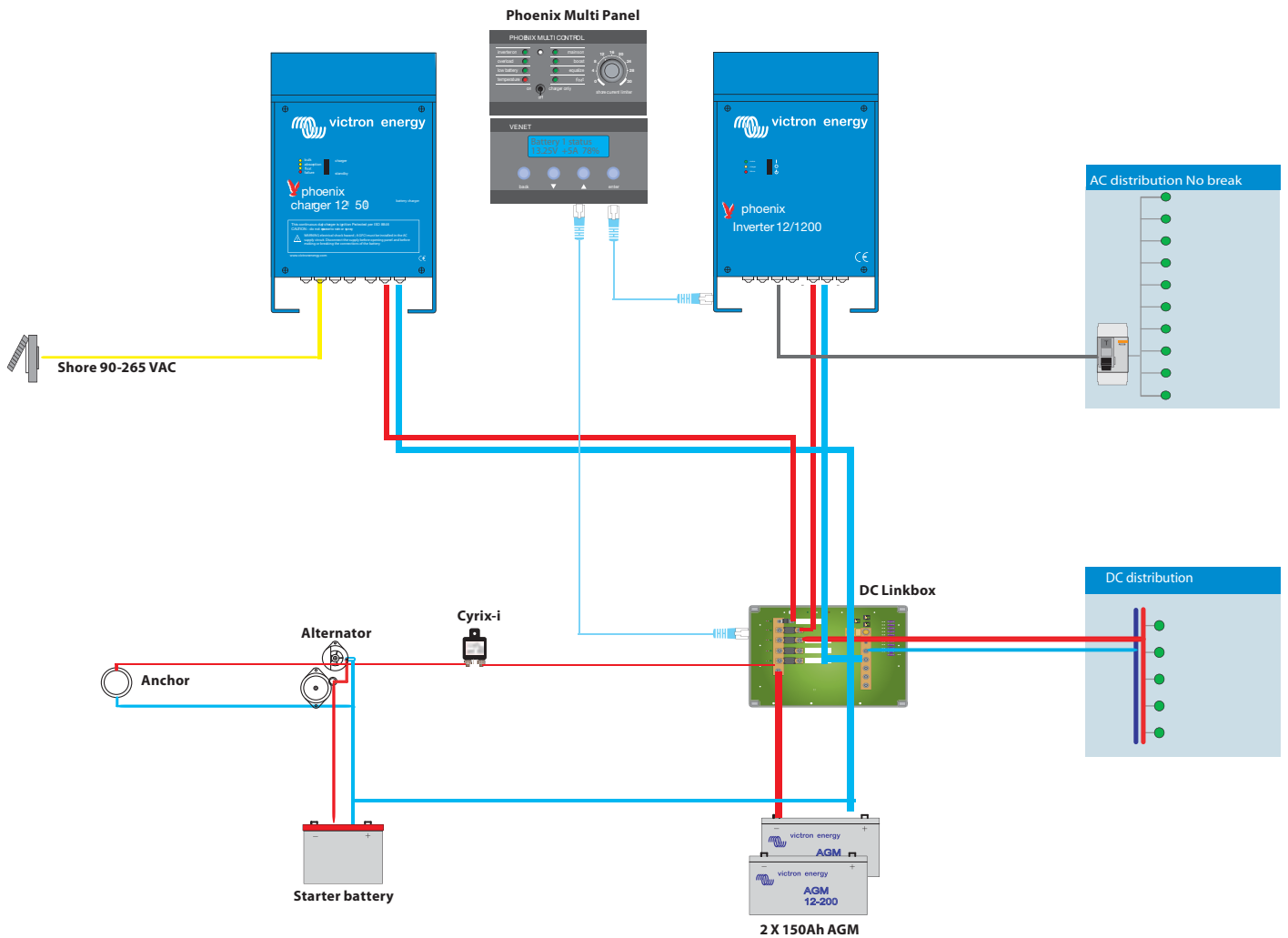

Victron Energy backs the Green Miles' aims and sponsored the project by providing an on-board sustainable energy supply. Green energy systems by Victron Energy are regularly used in remote places around the world to guarantee an independent energy supply. The energy provided on board of the Green Miles will therefore be sustainable as well as... comfortable!



Florian Dirkse and Arjen van Eijk

SYSTEMS

There are many ways to build a Victron Energy system. Here are a few examples of different systems, from a simple system with only DC consumers to larger parallel and three-phase systems.

1. Simple system with only DC consumers

The battery charger charges the battery and functions as a power supply for the consumers.

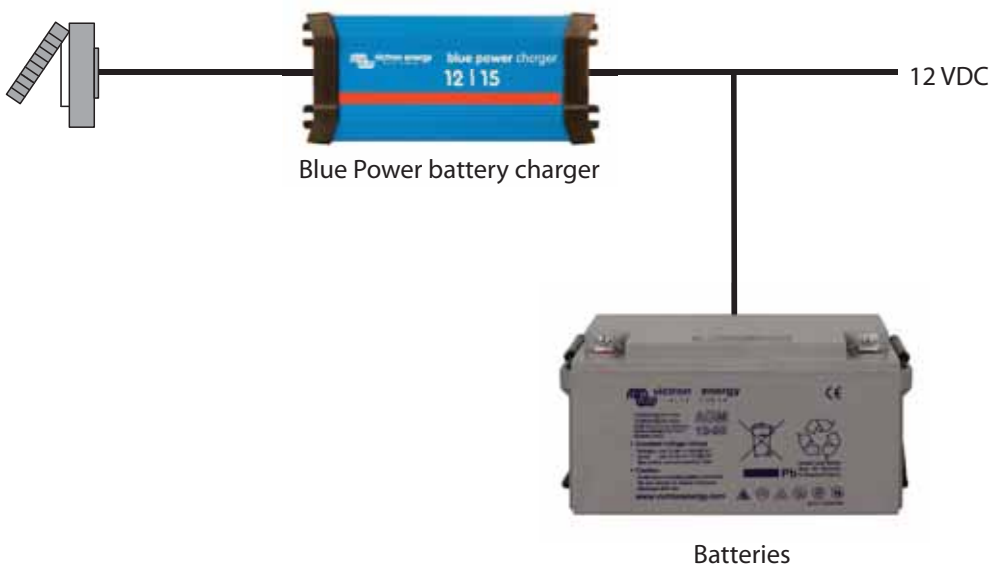

2. System with inverter

This system contains an inverter to ensure a supply of 230VAC at all times. Many charger models have three outputs which allow for several battery groups to be charged separately.

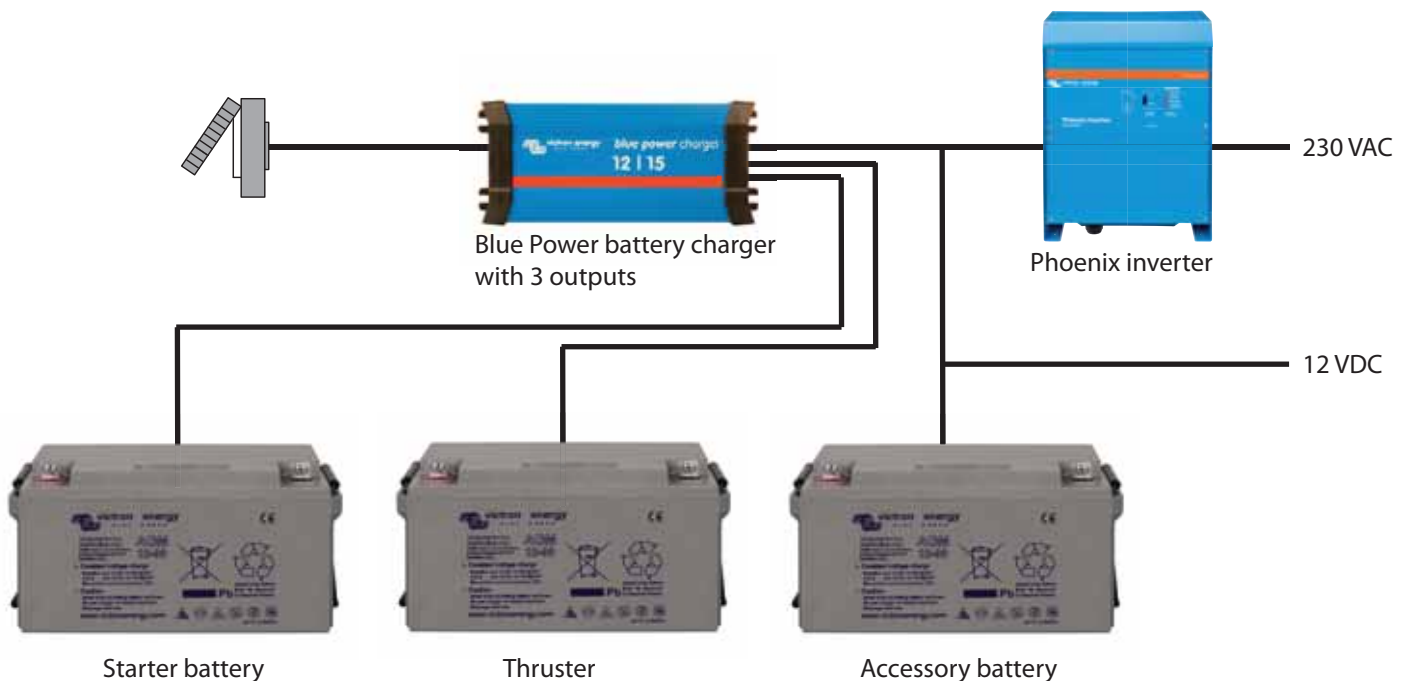

SYSTEMS

3. Multi-functional

The MultiPlus is a charger and inverter in one. It can function as a UPS (Uninterruptible Power Supply) to ensure power supply when the input power source fails. The MultiPlus also offers several other functional advantages such as PowerControl and PowerAssist.

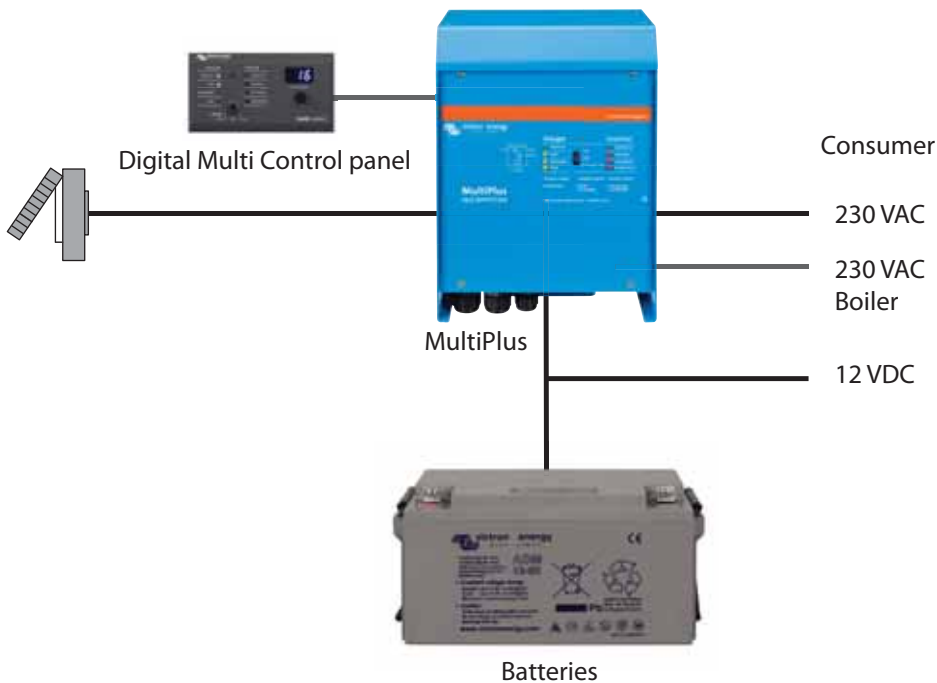

PowerAssist – boosting the capacity of shore or generator power

This unique Victron feature allows the MultiPlus to supplement the capacity of the shore or generator power. Where peak power is so often required only for a limited period, the MultiPlus will make sure that insufficient shore or generator power is immediately compensated with power from the battery. When the load reduces, the spare power is used to recharge the battery bank.

It is therefore no longer necessary to size a generator on the maximum peak load. Use the most efficient size generator instead.

Note: this feature is available in both the MultiPlus and the Quattro.

4. System with generator

The Quattro has the same functions as the MultiPlus, but with an extra addition: a transfer system which can be directly connected to shore power and a generator.

MultiPlus vs Quattro

The MultiPlus and Quattro products play a central role in both AC and DC systems. They are both powerful battery chargers and inverters in one box.

The amount of available AC sources is the deciding factor when choosing between the Quattro and the Multi.

The big difference is that a Quattro can take two AC sources, and switch between them based on intelligent rules. It has a built-in transfer-switch. The MultiPlus can take only one AC source.

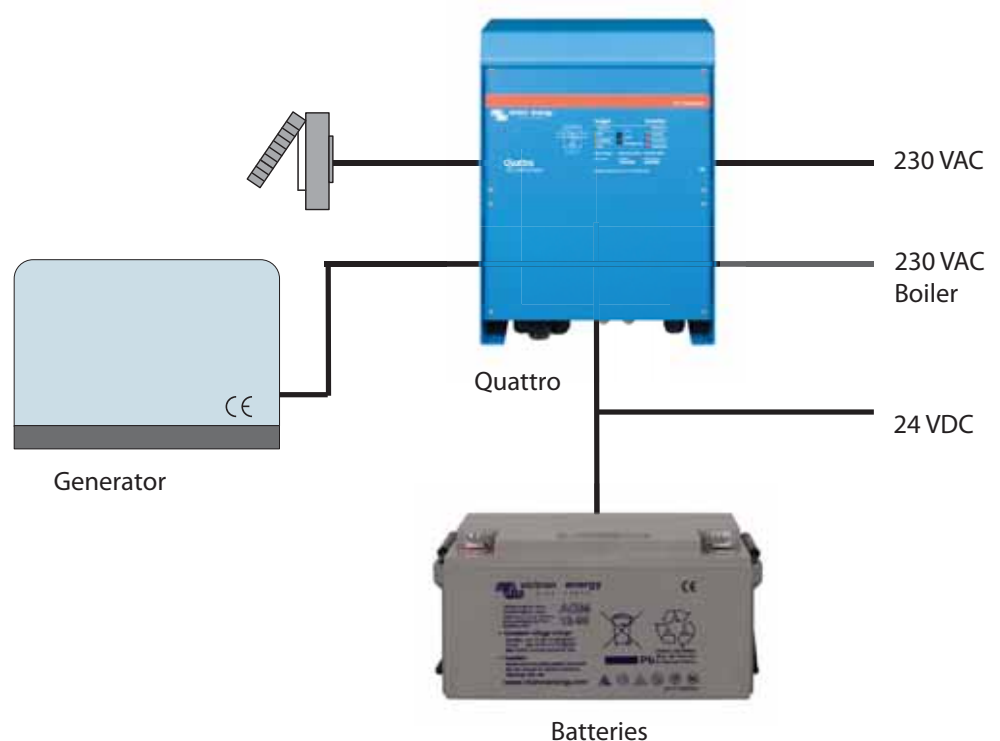

SYSTEMS

5. Using a DC Generator

In this MultiPlus-based system example the generator directly charges the batteries and/or feeds the inverters. This system offers a lot of advantages such as weight reduction and comfort.

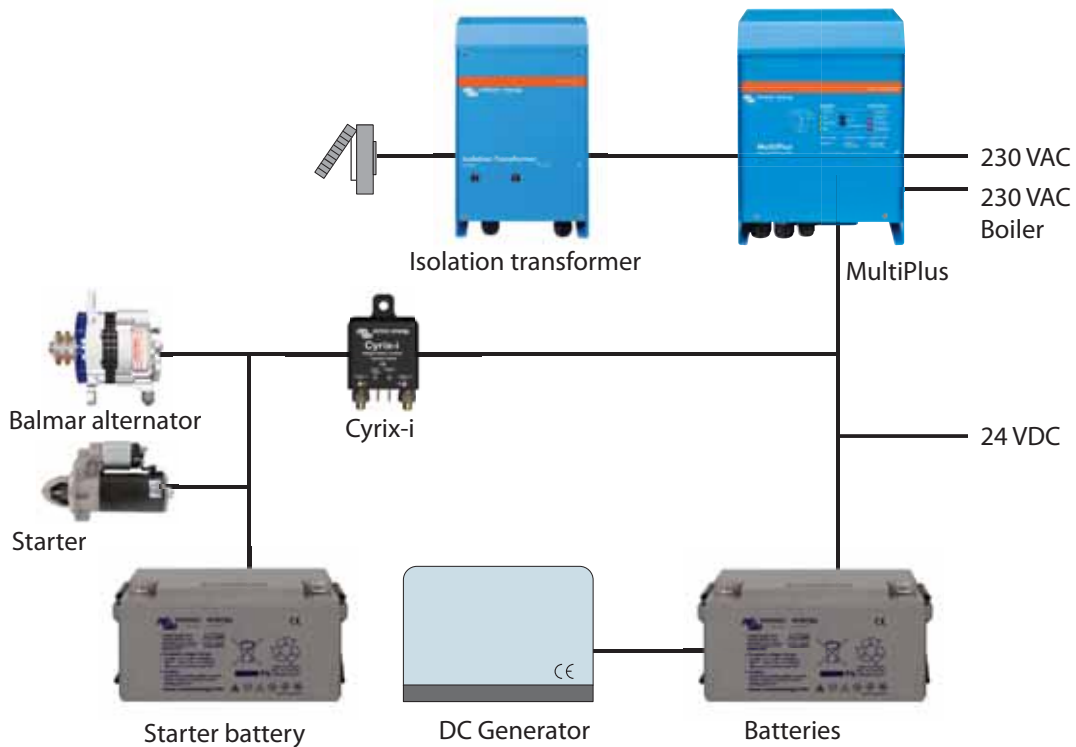

6. Using an AC Generator

This system example is based on a Quattro, which forms the heart of the system. Depending on how high the demand for power is, the Quattro will choose between battery- shore- and generator power.

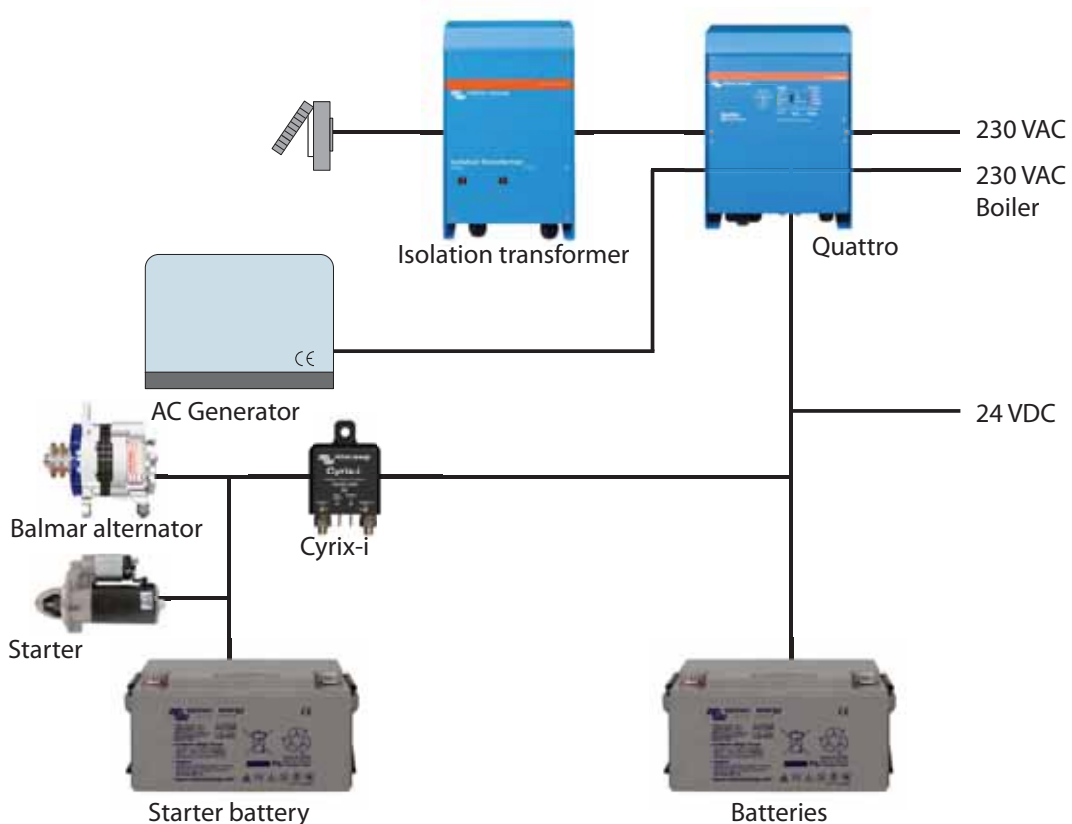

SYSTEMS

7. Parallel system

Our inverters, Multi's and Quattro's can be paralleled to meet higher power requirements. A simple setting with our VEConfigure configuration software is sufficient.

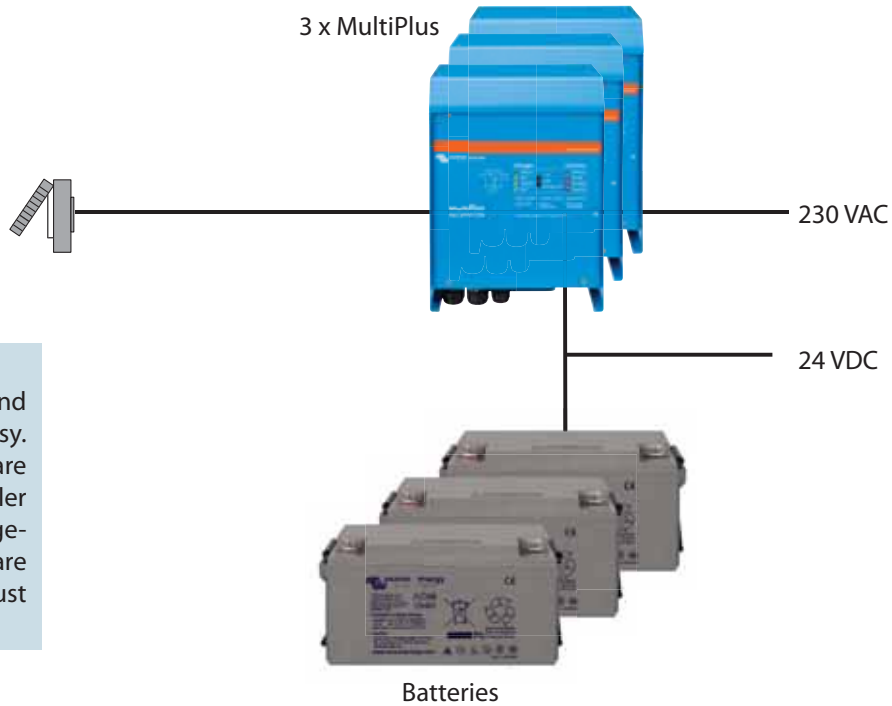

Easy to configure

Configuring parallel and three phase systems is easy. Our VEConfigure software tool allows the installer to put components together, without any hardware changes or dipswitches. Just using standard products.

8. Three-phase system

Similar to connecting units in parallel they can also be connected in split-phase and three-phase configurations.

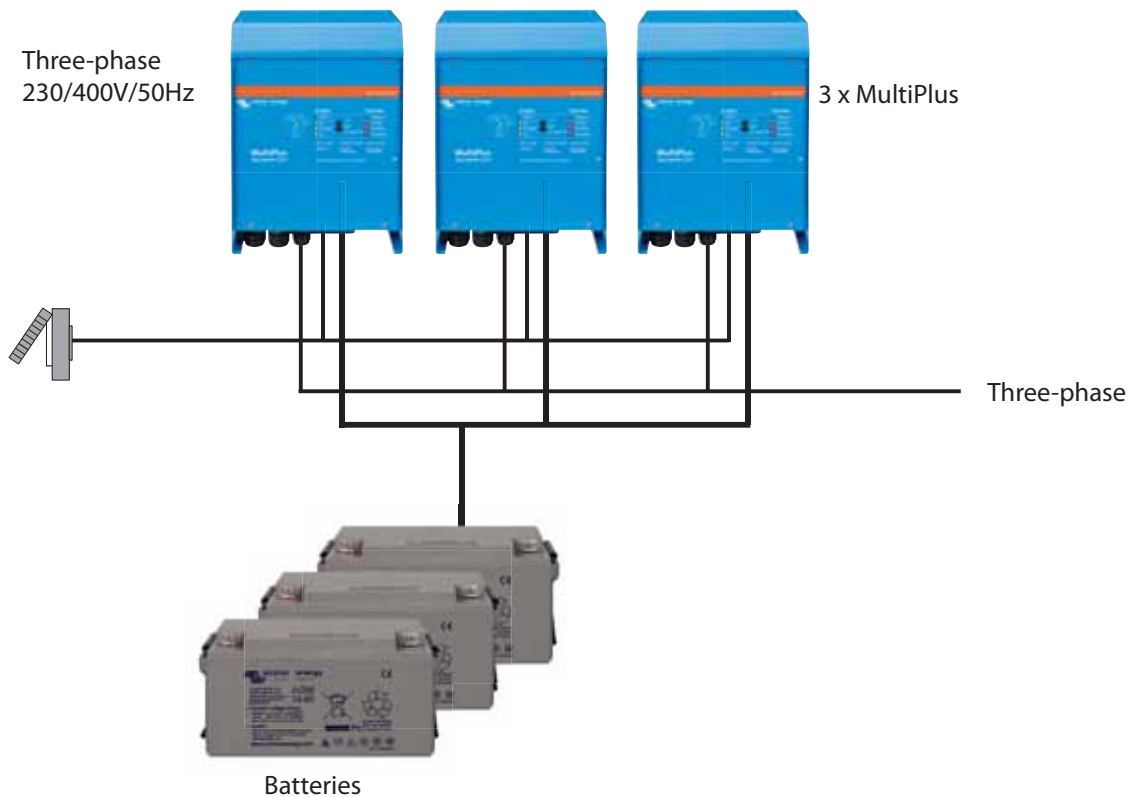

ACCESSORIES

Our systems are comprised of various components. Some of which are specifically designed for specific markets. Other Victron components are applicable for a wide range of applications. You are able to find the specifications and other detailed information about these components in the 'Technical Information' section.



Battery Monitor

Key tasks of the Victron Battery Monitor are measuring charge and discharge currents as well as calculating the state-of-charge and time-to-go of a battery. An alarm is sent when certain limits are exceeded (such as an excessive discharge). It is also possible for the battery monitor to exchange data with the Victron Global Remote. This includes sending alarms.



Color Control GX

The Color Control GX provides intuitive control and monitoring for all products connected to it. The list of Victron products that can be connected is endless: Inverters, Multi's, Quattro's, MPPT 150/70, BMV-600 series, BMV-700 series, Skylla-i, Lynx Ion and even more.



VRM Online Portal

Besides monitoring and controlling products on the Color Control GX, the information is also forwarded to our free remote monitoring website: the VRM Online Portal.

To get an impression of the VRM Online Portal, visit <https://vrm.victronenergy.com>, and use the 'Take a look inside' button. The portal is free of charge.



Digital Multi Control Panel

With this panel you are able to remotely monitor and control Multiplus and Quattro systems. A simple turn of the button can limit the power supply of for example a generator and/or shore-side current. The setting range is up to 200A.

ACCESSORIES



FILAX 2 Transfer switch

Filax 2: the ultra fast transfer switch

The Filax has been designed to switch sensitive loads, such as computers or modern entertainment equipment from one AC source to another. The priority source typically is the mains, a generator or shore power. The alternate source typically is an inverter.

Transfer switches 5kVA and 10kVA

The Transfer Switch is an automatic switching device between two different AC sources. Between generator and the grid, between an inverter and the grid or between the generator and an inverter.



BatteryProtect (Models: BP-40i, BP-60i, BP-200i)

The BatteryProtect disconnects the battery from non-essential loads before it is completely discharged (which would damage the battery) or before it has insufficient power left to crank the engine.



Shore power cable

- Waterproof Shore Power Cable and Inlet IP67
- Moulded Plug and Connector
- Power indication LED
- Protection Cap
- Stainless Steel Inlet



ESP system panel

The new ESP panel system provides a contemporary designed range of panels that cover the core engineering systems. The main system panel is the heart of the range. This provides AC and DC monitoring, Multi control and backlight control. Additional panels include AC and DC circuit breaker panels, a general control panel, a VE Net panel.

Note: for our newest datasheets please refer to our website:
www.victronenergy.com



TECHNICAL INFORMATION

Phoenix inverters 180VA - 1200VA 120V and 230V	26
Phoenix inverters 1200VA - 5000VA 230V	28
MultiPlus inverter/charger 800VA - 5kVA 230V	30
Quattro inverter/charger 3kVA - 10kVA 230V	32
MultiPlus inverter/charger 2kVA and 3kVA 120V	34
Quattro inverter/charger 3kVA and 5kVA 120V	36
Blue Power battery charger GX IP20	38
Blue Power battery charger GX IP20 12-25 and 24-12	39
Blue Power battery charger IP22	40
Blue Power battery charger IP65	41
Blue Power battery charger IP67 180 - 265VAC	42
Blue Power battery charger IP65 180 - 265VAC	44
Centaur charger 12/24V	48
Phoenix battery charger 12/24V	50
Skylla-i battery charger 24V	52
Skylla-TG charger 24/48V 230V	54
Skylla-TG charger 24V 90-265V GL approved	56
Skylla-TG 24/30 and 24/50 GMDSS	58
Isolation transformers	60
Orion DC/DC converters	62
Color Control GX	64
Blue Power panel	68
Cyrix-i 12/24V 120A and 225A	69
Cyrix-i 200A-400A 12/24V and 24/48V	70
BMV700 series: Precision battery monitoring	72
Argo diode battery isolators	74
Argo FET battery isolators	75
Overview BlueSolar charge controllers	76
BlueSolar charge controller MPPT 75/15 and MPPT 100/15	77
BlueSolar charge controller MPPT 100/30	78
BlueSolar charge controller MPPT 75/50 and MPPT 100/50	79
BlueSolar charge controller and MPPT 150/35	80
BlueSolar charge controller MPPT 150/70 and MPPT 150/85	81
BlueSolar charge controllers PWM	82
12,8 Volt Lithium iron phosphate batteries	84
BMS 12/200 for 12,8 Volt lithium iron phosphate batteries	86
24V 180Ah Lithium-ion battery and Lynx-ion	88
Ion control	90
Gel and AGM batteries	94
BlueSolar monocrystalline panels	98
BlueSolar polycrystalline panels	99
MultiPlus principle	100

PHOENIX INVERTERS 180VA - 1200VA 120V AND 230V



Phoenix Inverter
12/180

SinusMax – Superior engineering

Developed for professional duty, the Phoenix range of inverters is suitable for the widest range of applications. The design criteria have been to produce a true sine wave inverter with optimized efficiency but without compromise in performance. Employing hybrid HF technology, the result is a top quality product with compact dimensions, light in weight and capable of supplying power, problem-free, to any load.

Extra start-up power

A unique feature of the SinusMax technology is very high start-up power. Conventional high frequency technology does not offer such extreme performance. Phoenix inverters, however, are well suited to power up difficult loads such as computers and low power electric tools.

To transfer the load to another AC source: the automatic transfer switch

For our lower power models we recommend the use of our Filax Automatic Transfer Switch. The Filax features a very short switchover time (less than 20 milliseconds) so that computers and other electronic equipment will continue to operate without disruption.



Phoenix Inverter
12/800 with Schuko socket

LED diagnosis

Please see manual for a description.

Remote on/off switch

Connector for remote on/off switch available on all models.

DIP switch for 50/60Hz selection (48/350 model only)

Available with different output sockets

Please see pictures below.



Phoenix Inverter 12/350
with IEC-320 sockets



Phoenix Inverter 12/180
with Schuko socket



Phoenix Inverter 12/180
with Nema 5-15R sockets



Phoenix Inverter 12/800
with IEC-320 socket



Phoenix Inverter 12/800
with Schuko socket



Phoenix Inverter 12/800
with BS 1363 socket



Phoenix Inverter 12/800
with AN/NZS 3112 socket



Phoenix Inverter 12/800
with Nema 5-15R socket

PHOENIX INVERTERS 180VA - 1200VA 120V AND 230V

Phoenix Inverter	12 Volt 24 Volt 48 Volt	12/180 24/180	12/350 24/350 48/350	12/800 24/800 48/800	12/1200 24/1200 48/1200
Cont. AC power at 25 °C (VA) (3)		180	350	800	1200
Cont. power at 25 °C / 40 °C (W)		175 / 150	300 / 250	700 / 650	1000 / 900
Peak power (W)		350	700	1600	2400
Output AC voltage / frequency (4)		110VAC or 230VAC +/- 3% 50Hz or 60Hz +/- 0,1%			
Input voltage range (V DC)		10,5 - 15,5 / 21,0 - 31,0 / 42,0 - 62,0		9,2 - 17,3 / 18,4 - 34,0 / 36,8 - 68,0	
Low battery alarm (V DC)		11,0 / 22 / 44		10,9 / 21,8 / 43,6	
Low battery shut down (V DC)		10,5 / 21 / 42		9,2 / 18,4 / 36,8	
Low battery auto recovery (V DC)		12,5 / 25 / 50		12,5 / 25 / 50	
Max. efficiency (%)		87 / 88	89 / 89 / 90	91 / 93 / 94	92 / 94 / 94
Zero-load power (W)		2,6 / 3,8	3,1 / 5,0 / 6,0	6 / 5 / 4	6 / 5 / 6
Zero-load power in search mode		n. a.	n. a.	2	2
Protection (2)		a - e			
Operating temperature range		-40 to +50°C (fan assisted cooling)			
Humidity (non condensing)		max 95%			
ENCLOSURE					
Material & Colour		aluminium (blue Ral 5012)			
Battery-connection		1)	1)	1)	1)
Standard AC outlets		230V: IEC-320 (IEC-320 plug included), CEE 7/4 (Schuko) 120V: Nema 5-15R			
Other outlets (at request)		BS 1363 (United Kingdom) AN/NZS 3112 (Australia, New Zealand)			
Protection category		IP 20			
Weight (kg / lbs)		2,7 / 5,4	3,5 / 7,7	6,5 / 14,3	8,5 / 18,7
Dimensions (hwxwd in mm) (hwxwd in inches)		72x132x200 2.8x5.2x7.9	72x155x237 2.8x6.1x9.3	108x165x305 4.2x6.4x11.9	108x165x305 4.2x6.4x11.9
ACCESSORIES					
Remote on-off switch		Two pole connector			
Automatic transfer switch		Filax			
STANDARDS					
Safety		EN 60335-1			
Emission Immunity		EN55014-1 / EN 55014-2/ EN 61000-6-2 / EN 61000-6-3			
1) Battery cables of 1.5 meter (12/180 with cigarette plug) 2) Protection key: a) output short circuit b) overload c) battery voltage too high d) battery voltage too low e) temperature too high		3) Non linear load, crest factor 3:1 4) Frequency can be set by DIP switch (48/350 model only)			



Battery Alarm

An excessively high or low battery voltage is indicated by an audible and visual alarm, and a relay for remote signalling.



BMV Battery Monitor

The BMV Battery Monitor features an advanced microprocessor control system combined with high resolution measuring systems for battery voltage and charge/discharge current. Besides this, the software includes complex calculation algorithms to exactly determine the state of charge of the battery. The BMV selectively displays battery voltage, current, consumed Ah or time to go. The monitor also stores a host of data regarding performance and use of the battery.

PHOENIX INVERTERS 1200VA - 5000VA 230V



**Phoenix Inverter
24/5000**

SinusMax - Superior engineering

Developed for professional duty, the Phoenix range of inverters is suitable for the widest range of applications. The design criteria have been to produce a true sine wave inverter with optimised efficiency but without compromise in performance. Employing hybrid HF technology, the result is a top quality product with compact dimensions, light in weight and capable of supplying power, problem-free, to any load.

Extra start-up power

A unique feature of the SinusMax technology is very high start-up power. Conventional high frequency technology does not offer such extreme performance. Phoenix inverters, however, are well suited to power up difficult loads such as refrigeration compressors, electric motors and similar appliances.

Virtually unlimited power thanks to parallel and 3-phase operation capability

Up to 6 units inverters can operate in parallel to achieve higher power output. Six 24/5000 units, for example, will provide 24kW / 30kVA output power. Operation in 3-phase configuration is also possible.

To transfer the load to another AC source: the automatic transfer switch

If an automatic transfer switch is required we recommend using the MultiPlus inverter/charger instead. The switch is included in these products and the charger function of the MultiPlus can be disabled. Computers and other electronic equipment will continue to operate without disruption because the MultiPlus features a very short switchover time (less than 20 milliseconds).

Computer interface

All models have a RS-485 port. All you need to connect to your PC is our MK2 interface (see under accessories). This interface takes care of galvanic isolation between the inverter and the computer, and converts from RS-485 to RS-232. A RS-232 to USB conversion cable is also available. Together with our VEConfigure software, which can be downloaded free of charge from our website, all parameters of the inverters can be customised. This includes output voltage and frequency, over and under voltage settings and programming the relay. This relay can for example be used to signal several alarm conditions, or to start a generator. The inverters can also be connected to VENet, the new power control network of Victron Energy, or to other computerised monitoring and control systems.

New applications of high power inverters

The possibilities of paralleled high power inverters are truly amazing. For ideas, examples and battery capacity calculations please refer to our book "Energy Unlimited" (available free of charge from Victron Energy and downloadable from www.victronenergy.com).



**Phoenix Inverter Compact
24/1600**

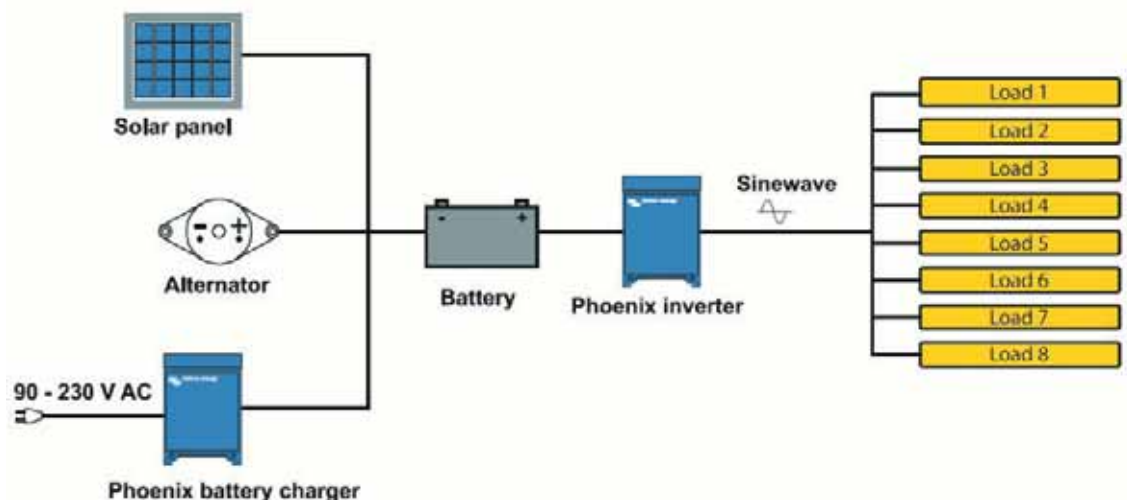

PHOENIX INVERTERS 1200VA - 5000VA 230V

Phoenix Inverter	C12/1200 C24/1200	C12/1600 C24/1600	C12/2000 C24/2000	12/3000 24/3000 48/3000	24/5000 48/5000
Parallel and 3-phase operation	Yes				
INVERTER					
Input voltage range (V DC)	9,5 – 17V 19 – 33V 38 – 66V				
Output	Output voltage: 230 VAC ±2% Frequency: 50 Hz ± 0,1% (1)				
Cont. output power at 25 °C (VA) (2)	1200	1600	2000	3000	5000
Cont. output power at 25 °C (W)	1000	1300	1600	2500	4500
Cont. output power at 40 °C (W)	900	1200	1450	2200	4000
Peak power (W)	2400	3000	4000	6000	10000
Max. efficiency 12/ 24 / 48 V (%)	92 / 94	92 / 94	92 / 92	93 / 94 / 95	94 / 95
Zero-load power 12 / 24 / 48 V (W)	8 / 10	8 / 10	9 / 11	15 / 15 / 16	25 / 25
Zero-load power in AES mode (W)	5 / 8	5 / 8	7 / 9	10 / 10 / 12	20 / 20
Zero-load power in Search mode (W)	2 / 3	2 / 3	3 / 4	4 / 5 / 5	5 / 6
GENERAL					
Programmable relay (3)	Yes				
Protection (4)	a - g				
VE.Bus communication port	For parallel and three phase operation, remote monitoring and system integration				
Remote on-off	Yes				
Common Characteristics	Operating temperature range: -40 to +50 °C (fan assisted cooling) Humidity (non condensing): max 95%				
ENCLOSURE					
Common Characteristics	Material & Colour: aluminum (blue RAL 5012) Protection category: IP 21				
Battery-connection	battery cables of 1.5 meter included		M8 bolts	2+2 M8 bolts	
230 V AC-connection	G-ST18i plug		Spring-clamp	Screw terminals	
Weight (kg)	10		12	18	30
Dimensions (hxwhd in mm)	375x214x110		520x255x125	362x258x218	444x328x240
STANDARDS					
Safety	EN 60335-1				
Emission Immunity	EN 55014-1 / EN 55014-2				
1) Can be adjusted to 60Hz and to 240V 2) Non linear load, crest factor 3:1 3) Programmable relay that can a.o. be set for general alarm, DC undervoltage or genset start/stop function. AC rating: 230V/4A DC rating: 4a up to 35VDC, 1A up to 60VDC	4) Protection key: a) output short circuit b) overload c) battery voltage too high d) battery voltage too low e) temperature too high f) 230 V AC on inverter output g) input voltage ripple too high				



Phoenix Inverter Control

This panel can also be used on a MultiPlus inverter/charger when an automatic transfer switch but no charger function is desired. The brightness of the LEDs is automatically reduced during night time.



Computer controlled operation and monitoring

Several interfaces are available:

- **MK2.2 VE.Bus to RS232 converter**
Connects to the RS232 port of a computer (see 'A guide to VEConfigure')
- **MK2-USB VE.Bus to USB converter**
Connects to a USB port (see 'A guide to VEConfigure')
- **VE.Net to VE.Bus converter**
Interface to VE.Net (see VE.Net documentation)
- **VE.Bus to NMEA 2000 converter**
- **Victron Global Remote**
The Global Remote is a modem which sends alarms, warnings and system status reports to cellular phones via text messages (SMS). It can also log data from Victron Battery Monitors, Multi's, Quattro's and Inverters to a website through a GPRS connection. Access to this website is free of charge.
- **Victron Ethernet Remote**
To connect to Ethernet.



BMV Battery Monitor

The BMV Battery Monitor features an advanced microprocessor control system combined with high resolution measuring systems for battery voltage and charge / discharge current. Besides this, the software includes complex calculation algorithms, like Peukert's formula, to exactly determine the state of charge of the battery. The BMV selectively displays battery voltage, current, consumed Ah or time to go. The monitor also stores a host of data regarding performance and use of the battery.

Several models available (see battery monitor documentation).

MULTIPLUS INVERTER/CHARGER 800VA - 5KVA 230V

Lithium Ion battery compatible



**MultiPlus
24/3000/70**

Multi-functional, with intelligent power management

The MultiPlus is a powerful true sine wave inverter, a sophisticated battery charger that features adaptive charge technology, and a high-speed AC transfer switch in a single compact enclosure. Next to these primary functions, the MultiPlus has several advanced features, as outlined below.

Two AC Outputs

The main output has no-break functionality. The MultiPlus takes over the supply to the connected loads in the event of a grid failure or when shore/generator power is disconnected. This happens so fast (less than 20 milliseconds) that computers and other electronic equipment will continue to operate without disruption. The second output is live only when AC is available on one of the inputs of the MultiPlus. Loads that should not discharge the battery, like a water heater for example, can be connected to this output (second output available on models rated at 3kVA and more).

Virtually unlimited power thanks to parallel operation

Up to 6 Multi's can operate in parallel to achieve higher power output. Six 24/5000/120 units, for example, will provide 25 kW / 30 kVA output power with 720 Amps charging capacity.

Three phase capability

In addition to parallel connection, three units of the same model can be configured for three-phase output. But that's not all: up to 6 sets of three units can be parallel connected for a huge 75 kW / 90 kVA inverter and more than 2000 Amps charging capacity.

PowerControl - Dealing with limited generator, shore side or grid power

The MultiPlus is a very powerful battery charger. It will therefore draw a lot of current from the generator or shore side supply (nearly 10A per 5kVA Multi at 230VAC). With the Multi Control Panel a maximum generator or shore current can be set. The MultiPlus will then take account of other AC loads and use whatever is extra for charging, thus preventing the generator or shore supply from being overloaded.

PowerAssist - Boosting the capacity of shore or generator power

This feature takes the principle of PowerControl to a further dimension. It allows the MultiPlus to supplement the capacity of the alternative source. Where peak power is so often required only for a limited period, the MultiPlus will make sure that insufficient shore or generator power is immediately compensated for by power from the battery. When the load reduces, the spare power is used to recharge the battery.

Four stage adaptive charger and dual bank battery charging

The main output provides a powerful charge to the battery system by means of advanced 'adaptive charge' software. The software fine-tunes the three stage automatic process to suit the condition of the battery, and adds a fourth stage for long periods of float charging. The adaptive charge process is described in more detail on the Phoenix Charger datasheet and on our website, under Technical Information. In addition to this, the MultiPlus will charge a second battery using an independent trickle charge output intended for a main engine or generator starter battery (trickle charge output available on 12V and 24V models only).

System configuring has never been easier

After installation, the MultiPlus is ready to go. If settings have to be changed, this can be done in a matter of minutes with a new DIP switch setting procedure. Even parallel and 3-phase operation can be programmed with DIP switches: no computer needed! Alternatively, VE.Net can be used instead of the DIP switches. And sophisticated software (VE.Bus Quick Configure and VE.Bus System Configurator) is available to configure several new, advanced, features.



**MultiPlus Compact
12/2000/80**

PowerAssist with 2x MultiPlus in parallel

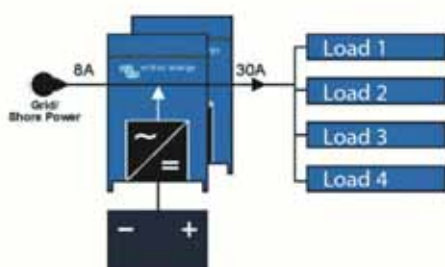

Five parallel units: output power 25 kVA

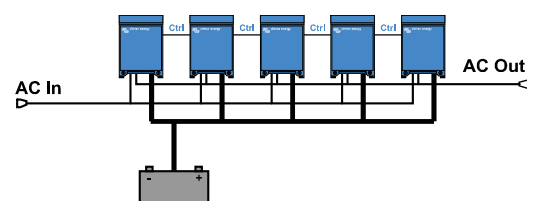

MULTIPLUS INVERTER/CHARGER 800VA - 5kVA 230V

MultiPlus	12 Volt 24 Volt 48 Volt	C 12/800/35 C 24/ 800/16	C 12/1200/50 C 24/1200/25	C 12/1600/70 C 24/1600/40	C 12/2000/80 C 24/2000/50	12/3000/120 24/3000/70 48/3000/35	24/5000/120 48/5000/70
PowerControl	Yes	Yes	Yes	Yes	Yes	Yes	Yes
PowerAssist	Yes	Yes	Yes	Yes	Yes	Yes	Yes
Transfer switch (A)	16	16	16	16	30	16 or 50	50 / 100
Parallel and 3-phase operation	Yes	Yes	Yes	Yes	Yes	Yes	Yes
INVERTER							
Input voltage range (V DC)	9,5 – 17 V 19 – 33 V 38 – 66 V						
Output	Output voltage: 230 VAC ± 2% Frequency: 50 Hz ± 0,1% (1)						
Cont. output power at 25 °C (VA) (3)	800	1200	1600	2000	3000	5000	
Cont. output power at 25 °C (W)	700	1000	1300	1600	2500	4500	
Cont. output power at 40 °C (W)	650	900	1200	1450	2200	4000	
Peak power (W)	1600	2400	3000	4000	6000	10.000	
Maximum efficiency (%)	92 / 94	93 / 94	93 / 94	93 / 94	93 / 94 / 95	94 / 95	
Zero-load power (W)	8 / 10	8 / 10	8 / 10	9 / 11	15 / 15 / 16	25 / 25	
Zero load power in AES mode (W)	5 / 8	5 / 8	5 / 8	7 / 9	10 / 10 / 12	20 / 20	
Zero load power in Search mode (W)	2 / 3	2 / 3	2 / 3	3 / 4	4 / 5 / 5	5 / 6	
CHARGER							
AC Input	Input voltage range: 187-265 VAC Input frequency: 45 – 65 Hz Power factor: 1						
Charge voltage 'absorption' (V DC)	14,4 / 28,8 / 57,6						
Charge voltage 'float' (V DC)	13,8 / 27,6 / 55,2						
Storage mode (V DC)	13,2 / 26,4 / 52,8						
Charge current house battery (A) (4)	35 / 16	50 / 25	70 / 40	80 / 50	120 / 70 / 35	120 / 70	
Charge current starter battery (A)	4 (12V and 24V models only)						
Battery temperature sensor	yes						
GENERAL							
Auxiliary output (5)	n. a.	n. a.	n. a.	n. a.	Yes (16A)	Yes (25A)	
Programmable relay (6)	Yes						
Protection (2)	a - g						
VE.Bus communication port	For parallel and three phase operation, remote monitoring and system integration						
General purpose com. port (7)	n. a.	n. a.	n. a.	n. a.	Yes (8)	Yes	
Remote on-off	Yes						
Common Characteristics	Operating temp. range: -40 to +50°C (fan assisted cooling) Humidity (non condensing): max 95%						
ENCLOSURE							
Common Characteristics	Material & Colour: aluminium (blue RAL 5012) Protection category: IP 21						
Battery-connection	battery cables of 1.5 meter			M8 bolts	Four M8 bolts (2 plus and 2 minus connections)		
230 V AC-connection	G-ST18i connector			Spring-clamp	Screw terminals 13 mm ² (6 AWG)		
Weight (kg)	10	10	10	12	18	30	
Dimensions (hwxwx in mm)	375x214x110			520x255x125	362x258x218	444x328x240	
STANDARDS							
Safety	EN 60335-1, EN 60335-2-29						
Emission, Immunity	EN55014-1, EN 55014-2, EN 61000-3-3						
Automotive Directive	2004/104/EC						
1) Can be adjusted to 60 HZ; 120 V 60 Hz on request	3) Non linear load, crest factor 3:1						
2) Protection key:	4) At 25 °C ambient						
a) output short circuit	5) Switches off when no external AC source available						
b) overload	6) Programmable relay that can a. o. be set for general alarm,						
c) battery voltage too high	DC undervoltage or genset start/stop function						
d) battery voltage too low	AC rating: 230V/4A						
e) temperature too high	DC rating: 4A up to 35VDC, 1A up to 60VDC						
f) 230 VAC on inverter output	7) A. o. to communicate with a Lithium Ion battery BMS						
g) input voltage ripple too high	8) Models with 16A transfer switch only (see Quattro for 50A transfer switch)						



Digital Multi Control

A convenient and low cost solution for remote monitoring, with a rotary knob to set Power Control and Power Assist levels.



Blue Power Panel

Connects to a Multi or Quattro and all VE.Net devices, in particular the VE.Net Battery Controller.
Graphic display of currents and voltages.



Computer controlled operation and monitoring

Several interfaces are available:

- **MK2.2 VE.Bus to RS232 converter**
Connects to the RS232 port of a computer (see 'A guide to VEConfigure')
- **MK2-USB VE.Bus to USB converter**
Connects to a USB port (see 'A guide to VEConfigure')
- **VE.Net to VE.Bus converter**
Interface to VE.Net (see VE.Net documentation)
- **VE.Bus to NMEA 2000 converter**
- **Victron Global Remote**
The Global Remote is a modem which sends alarms, warnings and system status reports to cellular phones via text messages (SMS). It can also log data from Victron Battery Monitors, Multi's, Quattro's and Inverters to a website through a GPRS connection. Access to this website is free of charge.
- **Victron Ethernet Remote**
To connect to Ethernet.



BMV Battery Monitor

The BMV Battery Monitor features an advanced microprocessor control system combined with high resolution measuring systems for battery voltage and charge/discharge current. Besides this, the software includes complex calculation algorithms, like Peukert's formula, to exactly determine the state of charge of the battery. The BMV selectively displays battery voltage, current, consumed Ah or time to go. The monitor also stores a host of data regarding performance and use of the battery.
Several models available (see battery monitor documentation).

QUATTRO INVERTER/CHARGER 3kVA - 10kVA 230V

Lithium Ion battery compatible

Two AC inputs with integrated transfer switch

The Quattro can be connected to two independent AC sources, for example shore-side power and a generator, or two generators. The Quattro will automatically connect to the active source.

Two AC Outputs

The main output has no-break functionality. The Quattro takes over the supply to the connected loads in the event of a grid failure or when shore/generator power is disconnected. This happens so fast (less than 20 milliseconds) that computers and other electronic equipment will continue to operate without disruption. The second output is live only when AC is available on one of the inputs of the Quattro. Loads that should not discharge the battery, like a water heater for example, can be connected to this output.

Virtually unlimited power thanks to parallel operation

Up to 10 Quattro units can operate in parallel. Ten units 48/10000/140, for example, will provide 90kW / 100kVA output power and 1400 Amps charging capacity.

Three phase capability

Three units can be configured for three-phase output. But that's not all: up to 10 sets of three units can be parallel connected to provide 270kW / 300kVA inverter power and more than 4000A charging capacity.

PowerControl – Dealing with limited generator, shore-side or grid power

The Quattro is a very powerful battery charger. It will therefore draw a lot of current from the generator or shore side supply (16A per 5kVA Quattro at 230VAC). A current limit can be set on each AC input. The Quattro will then take account of other AC loads and use whatever is spare for charging, thus preventing the generator or shore supply from being overloaded.

PowerAssist – Boosting shore or generator power

This feature takes the principle of PowerControl to a further dimension allowing the Quattro to supplement the capacity of the alternative source. Where peak power is so often required only for a limited period, the Quattro will make sure that insufficient shore or generator power is immediately compensated for by power from the battery. When the load reduces, the spare power is used to recharge the battery.

Solar energy: AC power available even during a grid failure

The Quattro can be used in off grid as well as grid connected PV and other alternative energy systems.

System configuring has never been easier

After installation, the Quattro is ready to go. If settings have to be changed, this can be done in a matter of minutes with a new DIP switch setting procedure. Even parallel and 3-phase operation can be programmed with DIP switches: no computer needed! Alternatively, VE.Net can be used instead of the DIP switches. And sophisticated software (VE.Bus Quick Configure and VE.Bus System Configurator) is available to configure several new, advanced, features.



Quattro
48/5000/70-100/100



Quattro
24/3000/70-50/30

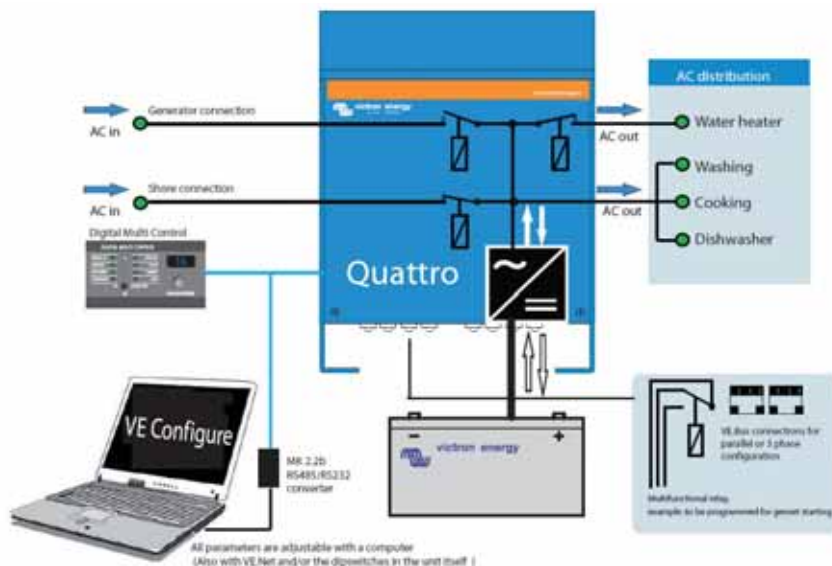

QUATTRO INVERTER/CHARGER 3kVA - 10kVA 230V

Quattro	12/3000/120-50/30 24/3000/70-50/30	12/5000/220-100/100 24/5000/120-100/100 48/5000/70-100/100	24/8000/200-100/100 48/8000/110-100/100	48/10000/140-100/100
PowerControl / PowerAssist	Yes			
Integrated Transfer switch	Yes			
AC inputs (2x)	Input voltage range: 187-265 VAC Input frequency: 45 – 65 Hz Power factor: 1			
Maximum feed through current (A)	50 / 30	2x100	2x100	2x100
INVERTER				
Input voltage range (V DC)	9,5 – 17V 19 – 33V 38 – 66V			
Output (1)	Output voltage: 230 VAC ± 2% Frequency: 50 Hz ± 0,1%			
Cont. output power at 25 °C (VA) (3)	3000	5000	8000	10000
Cont. output power at 25 °C (W)	2500	4500	7000	9000
Cont. output power at 40 °C (W)	2200	4000	6300	8000
Peak power (W)	6000	10000	16000	20000
Maximum efficiency (%)	93 / 94	94 / 94 / 95	94 / 96	96
Zero-load power (W)	15 / 15	25 / 25 / 25	30 / 35	35
Zero load power in AES mode (W)	10 / 10	20 / 20 / 20	25 / 30	30
Zero load power in Search mode (W)	4 / 5	5 / 5 / 6	8 / 10	10
CHARGER				
Charge voltage 'absorption' (V DC)	14,4 / 28,8	14,4 / 28,8 / 57,6	28,8 / 57,6	57,6
Charge voltage 'float' (V DC)	13,8 / 27,6	13,8 / 27,6 / 55,2	27,6 / 55,2	55,2
Storage mode (V DC)	13,2 / 26,4	13,2 / 26,4 / 52,8	26,4 / 52,8	52,8
Charge current house battery (A) (4)	120 / 70	220 / 120 / 70	200 / 110	140
Charge current starter battery (A)	4 (12V and 24V models only)			
Battery temperature sensor	Yes			
GENERAL				
Auxiliary output (A) (5)	25	50	50	50
Programmable relay (6)	1x	3x	3x	3x
Protection (2)	a-g			
VE.Bus communication port	For parallel and three phase operation, remote monitoring and system integration			
General purpose com. port (7)	1x	2x	2x	2x
Remote on-off	Yes			
Common Characteristics	Operating temp.: -40 to +50 °C Humidity (non condensing): max. 95%			
ENCLOSURE				
Common Characteristics	Material & Colour: aluminium (blue RAL 5012) Protection category: IP 21			
Battery-connection	Four M8 bolts (2 plus and 2 minus connections)			
230 V AC-connection	Screw terminals 13 mm ² (6 AWG)	Bolts M6	Bolts M6	Bolts M6
Weight (kg)	19	34 / 30 / 30	45/41	45
Dimensions (hwxwd in mm)	362 x 258 x 218	470 x 350 x 280 444 x 328 x 240 444 x 328 x 240	470 x 350 x 280	470 x 350 x 280
STANDARDS				
Safety	EN 60335-1, EN 60335-2-29			
Emission, Immunity	EN55014-1, EN 55014-2, EN 61000-3-3, EN 61000-6-3, EN 61000-6-2, EN 61000-6-1			
1) Can be adjusted to 60 Hz; 120 V 60 Hz on request	3) Non linear load, crest factor 3:1			
2) Protection key:	4) At 25 °C ambient			
a) output short circuit	5) Switches off when no external AC source available			
b) overload	6) Programmable relay that can a. o. be set for general alarm, DC undervoltage or genset start/stop function			
c) battery voltage too high	AC rating: 230V/4A			
d) battery voltage too low	DC rating: 4A up to 35VDC, 1A up to 60VDC			
e) temperature too high	7) A. o. to communicate with a Lithium Ion battery BMS			
f) 230 VAC on inverter output				
g) input voltage ripple too high				



Digital Multi Control Panel

A convenient and low cost solution for remote monitoring, with a rotary knob to set Power Control and Power Assist levels.



Blue Power Panel

Connects to a Multi or Quattro and all VE.Net devices, in particular the VE.Net Battery Controller. Graphic display of currents and voltages.



Computer controlled operation and monitoring

Several interfaces are available:

- **MK2.2 VE.Bus to RS232 converter**
Connects to the RS232 port of a computer (see 'A guide to VEConfigure')
- **MK2-USB VE.Bus to USB converter**
Connects to a USB port (see 'A guide to VEConfigure')
- **VE.Net to VE.Bus converter**
Interface to VE.Net (see VE.Net documentation)
- **VE.Bus to NMEA 2000 converter**
- **Victron Global Remote**
The Global Remote is a modem which sends alarms, warnings and system status reports to cellular phones via text messages (SMS). It can also log data from Victron Battery Monitors, Multi's, Quattro's and Inverters to a website through a GPRS connection. Access to this website is free of charge.
- **Victron Ethernet Remote**
To connect to Ethernet.



BMV Battery Monitor

The BMV Battery Monitor features an advanced microprocessor control system combined with high resolution measuring systems for battery voltage and charge/discharge current. Besides this, the software includes complex calculation algorithms, like Peukert's formula, to exactly determine the state of charge of the battery. The BMV selectively displays battery voltage, current, consumed Ah or time to go. The monitor also stores a host of data regarding performance and use of the battery. Several models available (see battery monitor documentation).

MULTIPLUS INVERTER/CHARGER 2KVA AND 3KVA 120V

Lithium Ion battery compatible



MultiPlus
24/3000/70



MultiPlus Compact
12/2000/80

Multi-functional, with intelligent power management

The MultiPlus is a powerful true sine wave inverter, a sophisticated battery charger that features adaptive charge technology, and a high-speed AC transfer switch in a single compact enclosure. Next to these primary functions, the MultiPlus has several advanced features, as outlined below.

Two AC Outputs

The main output has no-break functionality. The MultiPlus takes over the supply to the connected loads in the event of a grid failure or when shore/generator power is disconnected. This happens so fast (less than 20 milliseconds) that computers and other electronic equipment will continue to operate without disruption.

The second output is live only when AC is available on the input of the MultiPlus. Loads that should not discharge the battery, like a water heater for example, can be connected to this output (second output available on models rated at 3kVA and more).

Virtually unlimited power thanks to parallel operation

Up to six Multi's can operate in parallel to achieve higher power output. Six 24/3000/70 units, for example, provide 15kW / 18kVA output power with 420 Amps of charging capacity.

Three phase capability

In addition to parallel connection, three units can be configured for three-phase output. But that's not all: with three strings of six parallel units a 45kW / 54kVA three phase inverter and 1260A charger can be built.

Split phase options

Two units can be stacked to provide 120-0-120V, and additional units can be paralleled up to a total of 6 units per phase, to supply up to 30kW / 36kVA of split phase power.

Alternatively, a split phase AC source can be obtained by connecting our autotransformer (see data sheet on www.victronenergy.com) to a 'European' inverter programmed to supply 240V / 60Hz.

PowerControl - Dealing with limited generator, shore side or grid power

The MultiPlus is a very powerful battery charger. It will therefore draw a lot of current from the generator or shore side supply (nearly 20A per 3kVA MultiPlus at 120VAC). With the Multi Control Panel a maximum generator or shore current can be set. The MultiPlus will then take account of other AC loads and use whatever is extra for charging, thus preventing the generator or shore supply from being overloaded.

PowerAssist - Boosting the capacity of shore or generator power

This feature takes the principle of PowerControl to a further dimension. It allows the MultiPlus to supplement the capacity of the alternative source. Where peak power is so often required only for a limited period, the MultiPlus will make sure that insufficient shore or generator power is immediately compensated for by power from the battery. When the load reduces, the spare power is used to recharge the battery.

Four stage adaptive charger and dual bank battery charging

The main output provides a powerful charge to the battery system by means of advanced 'adaptive charge' software. The software fine-tunes the three stage automatic process to suit the condition of the battery, and adds a fourth stage for long periods of float charging. The adaptive charge process is described in more detail on the Phoenix Charger datasheet and on our website, under Technical Information. In addition to this, the MultiPlus will charge a second battery using an independent trickle charge output intended for a main engine or generator starter battery.

System configuring has never been easier

After installation, the MultiPlus is ready to go.

If settings have to be changed, this can be done in a matter of minutes with a DIP switch setting procedure. Even parallel and 3-phase operation can be programmed with DIP switches: no computer needed!

Alternatively, VE.Net can be used instead of the DIP switches.

And sophisticated software (VE.Bus Quick Configure and VE.Bus System Configurator) is available to configure several new, advanced, features.

PowerAssist with 2x MultiPlus in parallel

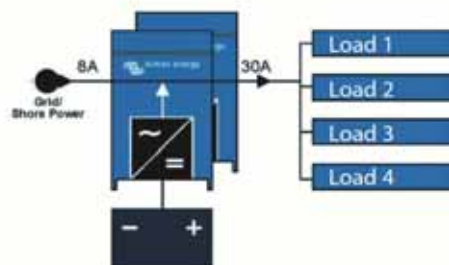

Five parallel units: output power 12,5 kW

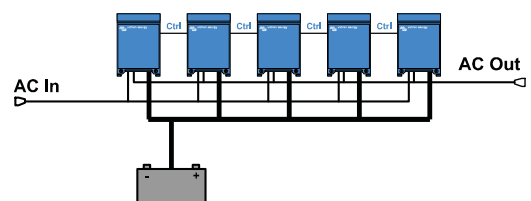

MULTIPLUS INVERTER/CHARGER 2KVA AND 3KVA 120V

MultiPlus	12 Volt 24 Volt	12/2000/80 24/2000/50	12/3000/120 24/3000/70
PowerControl			Yes
PowerAssist			Yes
Transfer switch (A)			50
Parallel and 3-phase operation			Yes
INVERTER			
Input voltage range (V DC)		9,5 – 17 V	19 – 33 V
Output		Output voltage: 120 VAC ± 2%	Frequency: 60 Hz ± 0,1% (1)
Cont. output power at 75 °F (VA) (3)		2000	3000
Cont. output power at 75 °F (W)		1600	2500
Cont. output power at 100 °F (W)		1450	2200
Peak power (W)		4000	6000
Maximum efficiency (%)		92 / 94	93 / 94
Zero-load power (W)		9 / 11	15 / 15
Zero load power in AES mode (W)		7 / 8	10 / 10
Zero load power in Search mode (W)		3 / 4	4 / 5
CHARGER			
AC Input		Input voltage range: 95-140 VAC	Input frequency: 45 – 65 Hz Power factor: 1
Charge voltage 'absorption' (V DC)			14,4 / 28,8
Charge voltage 'float' (V DC)			13,8 / 27,6
Storage mode (V DC)			13,2 / 26,4
Charge current house battery (A) (4)		80 / 50	120 / 70
Charge current starter battery (A)			4
Battery temperature sensor			yes
GENERAL			
Auxiliary output (5)		n. a.	Yes (32A)
Programmable relay (6)		Yes (1x)	Yes (3x)
Protection (2)			a - g
VE.Bus communication port		For parallel and three phase operation, remote monitoring and system integration	
General purpose com. port (7)		n. a.	Yes (2x)
Remote on-off			Yes
Common Characteristics		Operating temp. range: 0 - 120°F (fan assisted cooling)	Humidity (non condensing): max 95%
ENCLOSURE			
Common Characteristics		Material & Colour: aluminum (blue RAL 5012)	Protection category: IP 21
Battery-connection		M8 bolts	M8 bolts (2 plus and 2 minus connections)
120 V AC-connection		Screw-terminal 6 AWG (13mm ²)	Screw-terminal 6 AWG (13mm ²)
Weight		13kg 25 lbs	19kg 40 lbs
Dimensions (hwxwd in mm and inches)		520x255x125 mm 20.5x10.0x5.0 inch	362x258x218 mm 14.3x10.2x8.6 inch
STANDARDS			
Safety		EN 60335-1, EN 60335-2-29	
Emission Immunity		EN55014-1, EN 55014-2, EN 61000-3-3	
1) Can be adjusted to 60 Hz; 120 V 60 Hz on request		3) Non linear load, crest factor 3:1	
2) Protection key:		4) At 75 °F ambient	
a) output short circuit		5) Switches off when no external AC source available	
b) overload		6) Programmable relay that can a. o. be set for general alarm,	
c) battery voltage too high		DC undervoltage or genset start/stop function	
d) battery voltage too low		AC rating: 230V/4A	
e) temperature too high		DC rating: 4A up to 35VDC, 1A up to 60VDC	
f) 230 VAC on inverter output		7) A. o. to communicate with a Lithium Ion battery BMS	
g) input voltage ripple too high			



Digital Multi Control

A convenient and low cost solution for remote monitoring, with a rotary knob to set Power Control and Power Assist levels.



Blue Power Panel

Connects to a Multi or Quattro and all VE.Net devices, in particular the VE.Net Battery Controller. Graphic display of currents and voltages.



Computer controlled operation and monitoring

Several interfaces are available:

- **MK2.2 VE.Bus to RS232 converter**
Connects to the RS232 port of a computer (see 'A guide to VEConfigure')
- **MK2-USB VE.Bus to USB converter**
Connects to a USB port (see 'A guide to VEConfigure')
- **VE.Net to VE.Bus converter**
Interface to VE.Net (see VE.Net documentation)
- **VE.Bus to NMEA 2000 converter**
- **Victron Global Remote**
The Global Remote is a modem which sends alarms, warnings and system status reports to cellular phones via text messages (SMS). It can also log data from Victron Battery Monitors, Multi's, Quattro's and Inverters to a website through a GPRS connection. Access to this website is free of charge.
- **Victron Ethernet Remote**
To connect to Ethernet.



BMV Battery Monitor

The BMV Battery Monitor features an advanced microprocessor control system combined with high resolution measuring systems for battery voltage and charge/discharge current. Besides this, the software includes complex calculation algorithms, like Peukert's formula, to exactly determine the state of charge of the battery. The BMV selectively displays battery voltage, current, consumed Ah or time to go. The monitor also stores a host of data regarding performance and use of the battery.

QUATTRO INVERTER/CHARGER 3KVA AND 5KVA 120V

Lithium Ion battery compatible

Two AC inputs with integrated transfer switch

The Quattro can be connected to two independent AC sources, for example shore-side power and a generator, or two generators. The Quattro will automatically connect to the active source.

Two AC Outputs

The main output has no-break functionality. The Quattro takes over the supply to the connected loads in the event of a grid failure or when shore/generator power is disconnected. This happens so fast (less than 20 milliseconds) that computers and other electronic equipment will continue to operate without disruption.

The second output is live only when AC is available on one of the inputs of the Quattro. Loads that should not discharge the battery, like a water heater for example, can be connected to this output.

Virtually unlimited power thanks to parallel operation

Up to 10 Quattro units can operate in parallel. Ten units 48/5000/70, for example, will provide 45kW / 50kVA output power and 700 Amps charging capacity.

Three phase capability

Three units can be configured for three-phase output. But that's not all: up to 10 sets of three units can be parallel connected to provide 135kW / 150kVA inverter power and more than 2000A charging capacity.

Split phase options

Two units can be stacked to provide 120-0-120V, and additional units can be paralleled up to a total of 6 units per phase, to supply up to 30kW / 36kVA of split phase power.

Alternatively, a split phase AC source can be obtained by connecting our autotransformer (see data sheet on www.victronenergy.com) to a 'European' inverter programmed to supply 240V / 60Hz.

PowerControl – Dealing with limited generator, shore-side or grid power

The Quattro is a very powerful battery charger. It will therefore draw a lot of current from the generator or shore side supply (Up to 40A per 5kVA Quattro at 120VAC). A current limit can be set on each AC input. The Quattro will then take account of other AC loads and use whatever is spare for charging, thus preventing the generator or shore supply from being overloaded.

PowerAssist – Boosting shore or generator power

This feature takes the principle of PowerControl to a further dimension allowing the Quattro to supplement the capacity of the alternative source. Where peak power is so often required only for a limited period, the Quattro will make sure that insufficient shore or generator power is immediately compensated for by power from the battery. When the load reduces, the spare power is used to recharge the battery.

Solar energy: AC power available even during a grid failure

The Quattro can be used in off grid as well as grid connected PV and other alternative energy systems.

System configuring has never been easier

After installation, the Quattro is ready to go.

If settings have to be changed, this can be done in a matter of minutes with a new DIP switch setting procedure. Even parallel and 3-phase operation can be programmed with DIP switches: no computer needed!

Alternatively, VE.Net can be used instead of the DIP switches.

And sophisticated software (VE.Bus Quick Configure and VE.Bus System Configurator) is available to configure several new, advanced, features.



Quattro
24/5000/120-100/100

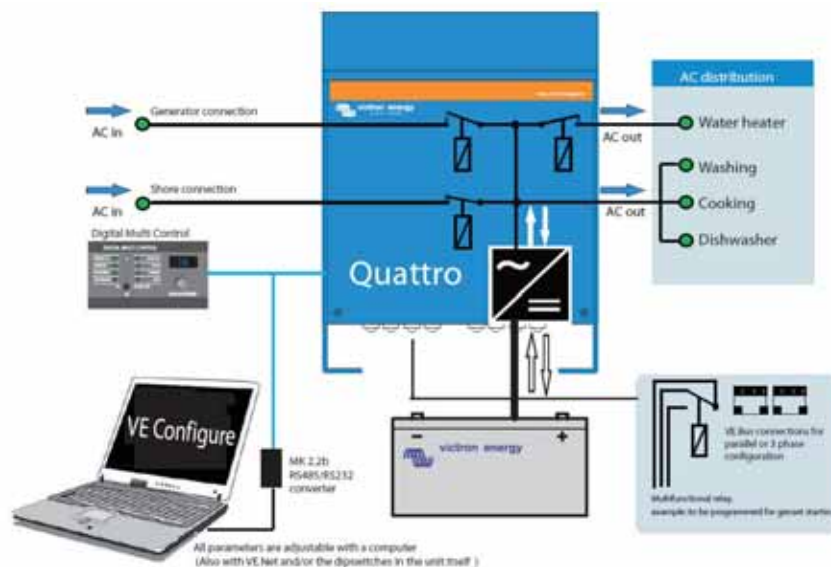

QUATTRO INVERTER/CHARGER 3KVA AND 5KVA 120V

Quattro	12/5000/200-100/100 120V	24/5000/120-100/100 120V	48/3000/35-50/50 120V	48/5000/70-100/100 120V
PowerControl / PowerAssist	Yes			
Integrated Transfer switch	Yes			
AC inputs (2x)	Input voltage range: 90-140 VAC Input frequency: 45 – 65 Hz Power factor: 1			
Maximum feed through current (A)	2x100	2x100	2x50	2x100
INVERTER				
Input voltage range (V DC)	9,5 - 17	19 – 33	37,2 – 64,4	37,2 – 64,4
Output (1)	Output voltage: 120 VAC ± 2%		Frequency: 60 Hz ± 0,1%	
Cont. output power at 25 °C (VA) (3)	5000	5000	3000	5000
Cont. output power at 25 °C (W)	4500	4500	2500	4500
Cont. output power at 40 °C (W)	4000	4000	2200	4000
Peak power (W)	10000	10000	6000	10000
Maximum efficiency (%)	94	94	94	95
Zero-load power (W)	25	25	15	25
Zero load power in AES mode (W)	20	20	10	20
Zero load power in Search mode (W)	5	5	5	6
CHARGER				
Charge voltage 'absorption' (V DC)	14,4	28,8	57,6	57,6
Charge voltage 'float' (V DC)	13,8	27,6	55,2	55,2
Storage mode (V DC)	13,2	26,4	52,8	52,8
Charge current house battery (A) (4)	200	120	35	70
Charge current starter battery (A)	4	4	n.a.	n.a.
Battery temperature sensor	Yes			
GENERAL				
Auxiliary output (A) (5)	50	50	32	50
Programmable relay (6)	3x	3x	3x	3x
Protection (2)	a-g			
VE.Bus communication port	For parallel and three phase operation, remote monitoring and system integration			
General purpose com. port (7)	Yes, 2x			
Remote on-off	Yes			
Common Characteristics	Operating temp.: -20 to +50 °C (0 - 120°F) Humidity (non condensing): max. 95%			
ENCLOSURE				
Common Characteristics	Material & Colour: aluminium (blue RAL 5012) Protection category: IP 21			
Battery-connection	Four M8 bolts (2 plus and 2 minus connections)			
230 V AC-connection	M6 bolts	M6 bolts	Screw terminals 13 mm ² (6 AWG)	M6 bolts
Weight (kg)	75 lb 34 kg	66 lb 30 kg	42 lb 19 kg	66 lb 30 kg
Dimensions (hxwx d)	18,5 x 14,0 x 11,2 inch 470 x 350 x 280 mm	17,5 x 13,0 x 9,6 inch 444 x 328 x 240 mm	14.3x10.2x8.6 inch 362x258x218 mm	17,5 x 13,0 x 9,6 inch 444 x 328 x 240 mm
STANDARDS				
Safety	EN 60335-1, EN 60335-2-29			
Emission, Immunity	EN55014-1, EN 55014-2, EN 61000-3-3			
1) Can be adjusted to 50 Hz	3) Non linear load, crest factor 3:1			
2) Protection key:	4) At 25 °C ambient 5) Switches off when no external AC source available			
a) output short circuit	5) Switches off when no external AC source available			
b) overload	6) Programmable relay that can be set for general alarm, DC undervoltage or genset start/stop function			
c) battery voltage too high	AC rating: 120V/4A			
d) battery voltage too low	DC rating: 4A up to 35VDC, 1A up to 60VDC			
e) temperature too high	7) A. o. to communicate with a Lithium Ion battery BMS			
f) 120 VAC on inverter output				
g) input voltage ripple too high				



Digital Multi Control

A convenient and low cost solution for remote monitoring, with a rotary knob to set Power Control and Power Assist levels.



Blue Power Panel

Connects to a Multi or Quattro and all VE.Net devices, in particular the VE.Net Battery Controller. Graphic display of currents and voltages.



Computer controlled operation and monitoring

Several interfaces are available:

- **MK2.2 VE.Bus to RS232 converter**
Connects to the RS232 port of a computer (see 'A guide to VEConfigure')
- **MK2-USB VE.Bus to USB converter**
Connects to a USB port (see 'A guide to VEConfigure')
- **VE.Net to VE.Bus converter**
Interface to VE.Net (see VE.Net documentation)
- **VE.Bus to NMEA 2000 converter**
- **Victron Global Remote**
The Global Remote is a modem which sends alarms, warnings and system status reports to cellular phones via text messages (SMS). It can also log data from Victron Battery Monitors, Multi's, Quattro's and Inverters to a website through a GPRS connection. Access to this website is free of charge.
- **Victron Ethernet Remote**
To connect to Ethernet.



BMV Battery Monitor

The BMV Battery Monitor features an advanced microprocessor control system combined with high resolution measuring systems for battery voltage and charge/discharge current. Besides this, the software includes complex calculation algorithms, like Peukert's formula, to exactly determine the state of charge of the battery. The BMV selectively displays battery voltage, current, consumed Ah or time to go. The monitor also stores a host of data regarding performance and use of the battery.

BLUE POWER BATTERY CHARGER GX IP20

180-265VAC



**Blue Power Battery Charger
GX IP 20 12/15**

The highest efficiency ever!

With up to 95% efficiency, these chargers generate up to **four times less heat** when compared to the industry standard.

And once the battery is fully charged, power consumption reduces to 0,5 Watt, some **five to ten times better** than the industry standard.

Adaptive 4-stage charge algorithm: bulk – absorption – float – storage

The Blue Power charger features a microprocessor controlled 'adaptive' battery management. The 'adaptive' feature will automatically optimize the charging process relative to the way the battery is being used.

Less maintenance and aging when the battery is not in use: the Storage Mode

The storage mode kicks in whenever the battery has not been subjected to discharge during 24 hours. In the storage mode float voltage is reduced to 2,2 V/cell (13,2 V for a 12 V battery) to minimize gassing and corrosion of the positive plates. Once a week the voltage is raised back to the absorption level to 'equalize' the battery. This feature prevents stratification of the electrolyte and sulphation, a major cause of early battery failure.

Totally silent

No fan.

Protected against overheating

Output current will reduce as temperature increases up to 60°C, but the Blue Power charger will not fail.

Two LED's for status indication

Yellow LED: bulk charge (blinking fast), absorption (blinking slow), float (solid), storage (off)

Green LED: power on

Learn more about batteries and battery charging

To learn more about batteries and charging batteries, please refer to our book 'Energy Unlimited' (available free of charge from Victron Energy and downloadable from www.victronenergy.com).

Blue Power Charger GX IP 20	12/7 (1) 12/10 (1) 12/15 (1)	24/5 (1) 24/8 (1)
Input voltage range	180-265 VAC or 250-350 VDC	
Efficiency	94%	95%
No load power consumption	0.5W	0.5W
Frequency	45-65 Hz or DC	
Number of outputs	1	1
Charge voltage 'absorption' (V DC)	14,4	28,8
Charge voltage 'float' (V DC)	13.8	27.6
Charge voltage 'storage' (V DC)	13,2	26,4
Charge current (A)	7 / 10 / 15	5 / 8
Charge characteristic	4-stage adaptive	
Minimum battery capacity (Ah)	24 / 30 / 45	16 / 24
Can be used as power supply	Yes	
Protection	Battery reverse polarity (fuse)	Output short circuit Over temperature
Operating temp. range	-20 to +60°C (full rated output up to 40°C)	
Humidity (non condensing)	Max 95 %	
Cooling	Natural convection (no fan)	
ENCLOSURE		
Material & Colour	Aluminium (blue RAL 5012)	
Battery-connection	Black and red cable of 1,5 meter with battery clamps	
230 V AC-connection	Cable of 1,5 meter with CEE 7/7 plug, BS 1363 plug (UK) or AS/NZS 3112 plug (AU/NZ)	
Protection category	IP 20	
Weight (kg)	1,3	
Dimensions (h x w x d in mm)	66 x 90 x 235	
STANDARDS		
Safety	EN 60335-1, EN 60335-2-29	
Emission	EN 55014-1, EN 61000-6-3, EN 61000-3-2	
Immunity	EN 55014-2, EN 61000-6-1, EN 61000-6-2, EN 61000-3-3	

BLUE POWER BATTERY CHARGER GX IP20 12-25 AND 24-12

180-265VAC



**Blue Power Battery Charger
GX IP 20 12/25 (1)**



**Blue Power Battery Charger
GX IP 20 24/15 (3)**

Adaptive 4-stage charge characteristic: bulk – absorption – float – storage

The Blue Power charger features a microprocessor controlled 'adaptive' battery management. The 'adaptive' feature will automatically optimize the charging process relative to the way the battery is being used.

Less maintenance and aging when the battery is not in use: the Storage Mode

The storage mode kicks in whenever the battery has not been subjected to discharge during 24 hours. In the storage mode float voltage is reduced to 2,2 V/cell (13,2 V for a 12 V battery) to minimize gassing and corrosion of the positive plates. Once a week the voltage is raised back to the absorption level to 'equalize' the battery. This feature prevents stratification of the electrolyte and sulfation, a major cause of early battery failure.

Protected against overheating and silent fan cooling

Output current will reduce as temperature increases up to 60°C, but the Blue Power charger will not fail. The load and temperature controlled fan is practically inaudible.

Two LED's for status indication

Yellow LED: bulk charge (blinking fast), absorption (blinking slow), float (solid), storage (off)
 Green LED: power on

Learn more about batteries and battery charging

To learn more about batteries and charging batteries, please refer to our book 'Energy Unlimited' (available free of charge from Victron Energy and downloadable from www.victronenergy.com).

Blue Power Charger GX IP 20	12/25 (1) 12/25 (3)	24/12 (1) 24/15 (3)
Input voltage range	180-265 VAC or 250-350 VDC	180-265 VAC or 250-350 VDC
Frequency	45-65 Hz or DC	
Number of outputs	1 or 3	1 or 3
Charge voltage 'absorption' (V DC)	14,4	28,8
Charge voltage 'float' (V DC)	14	28
Charge voltage 'storage' (V DC)	13,2	26,4
Charge current (A)	25	12 or 15
Charge characteristic	4-stage adaptive	
Minimum battery capacity (Ah)	75	45
Can be used as power supply	Yes	
Protection	Battery reverse polarity (fuse)	Output short circuit Over temperature
Operating temp. range	-20 to +60°C (full rated output up to 40°C)	
Humidity (non condensing)	Max 95 %	
Cooling	Fan assisted	
ENCLOSURE		
Material & Colour	Aluminium (blue RAL 5012)	
Battery-connection	One output: black and red cable of 1,5 meter	Three outputs: screw terminals 6 mm ²
230 V AC-connection	Cable of 1,5 meter with CEE 7/7 or AS/NZS 3112 plug	
Protection category	IP 20	
Weight (kg)	1,3	
Dimensions (h x w x d in mm)	66 x 90 x 235	
STANDARDS		
Safety	EN 60335-1, EN 60335-2-29	
Emission	EN 55014-1, EN 61000-6-3, EN 61000-3-2	
Immunity	EN 55014-2, EN 61000-6-1, EN 61000-6-2, EN 61000-3-3	

BLUE POWER BATTERY CHARGER IP22 180 - 165 VAC



Blue Power Battery Charger
IP22 12/30 (3)

High efficiency

With up to 94% efficiency, these chargers generate up to four times less heat when compared to the industry standard.

And once the battery is fully charged, power consumption reduces to 0,5 Watt, some five to ten times better than the industry standard.

Adaptive 6-stage charge algorithm: test - bulk – absorption - recondition – float – storage

The Blue Power charger features a microprocessor controlled 'adaptive' battery management. The adaptive feature will automatically optimize the charging process relative to the way the battery is being used.

Storage Mode: less maintenance and aging when the battery is not in use

The storage mode kicks in whenever the battery has not been subjected to discharge during 24 hours. In the storage mode float voltage is reduced to 2,2 V/cell (13,2 V for a 12 V battery) to minimize gassing and corrosion of the positive plates. Once a week the voltage is raised back to the absorption level to 'equalize' the battery. This feature prevents stratification of the electrolyte and sulfation, a major cause of early battery failure.

Also charges Li-ion (LiFePO₄) batteries

LiFePO₄ batteries are charged with a simple bulk – absorption – float algorithm.

NIGHT and LOW setting

When in NIGHT or LOW mode, the output current is reduced to max. 25% of the nominal output and the charger will be totally noiseless. The NIGHT mode automatically ends after 8 hours. The LOW mode can be ended manually.

Protected against overheating

Output current will reduce as temperature increases up to 50°C, but the Blue Power charger will not fail.

Eleven LED's for Status indication

Charge algorithm: TEST / BULK / ABSORPTION / RECONDITION / FLOAT / STORAGE / READY
MODE button to set: NORMAL (14,4 V) / HIGH (14,7 V) / RECONDITION / LI-ION

Blue Power Charger	12/30 (1)			12/30 (3)			24/15 (1)			24/15 (3)		
Input voltage range	180–265 VAC						180–265 VAC					
Charge current, normal mode	30 A						15 A					
Charge current, NIGHT or LOW	7,5 A						3,75 A					
Efficiency	93%						94%					
No load power consumption	0,5W						0,5W					
Frequency	45–65 Hz						45–65 Hz					
Number of outputs	1			3			1			3		
Charge voltage 'absorption'	Normal: 14,4 V	High: 14,6 V	Li-ion: 14,2 V	Normal: 28,8 V	High: 29,2 V	Li-ion: 28,4 V	Normal: 28,8 V	High: 29,2 V	Li-ion: 28,4 V	Normal: 28,8 V	High: 29,2 V	Li-ion: 28,4 V
Charge voltage 'float'	Normal: 13,8 V	High: 13,8 V	Li-ion: 13,35 V	Normal: 27,6 V	High: 27,6 V	Li-ion: 26,7 V	Normal: 27,6 V	High: 27,6 V	Li-ion: 26,7 V	Normal: 27,6 V	High: 27,6 V	Li-ion: 26,7 V
Charge voltage 'storage'	Normal: 13,2 V	High: 13,8 V	Li-ion: n. a.	Normal: 26,4 V	High: 26,4 V	Li-ion: n. a.	Normal: 26,4 V	High: 26,4 V	Li-ion: n. a.	Normal: 26,4 V	High: 26,4 V	Li-ion: n. a.
Charge algorithm	6-stage adaptive											
Can be used as power supply	Yes											
Protection	Battery reverse polarity (fuse)			Output short circuit			Over temperature					
Operating temp. range	-20 to +50°C											
Humidity (non condensing)	Max 98 %											
ENCLOSURE												
Material & Colour	Aluminum (blue RAL 5012)											
Battery connection	Screw terminals 13 mm ² / AWG6											
230 V AC connection	Cable of 1,5 meter with CEE 7/7 plug, BS 1363 plug (UK) or AS/NZS 3112 plug (AU/NZ)											
Protection category	IP22											
Weight	1,3 kg											
Dimensions (h x w x d)	235 x 108 x 65 mm											
STANDARDS												
Safety	EN 60335-1, EN 60335-2-29											
Emission	EN 55014-1, EN 61000-6-3, EN 61000-3-2											
Immunity	EN 55014-2, EN 61000-6-1, EN 61000-6-2, EN 61000-3-3											

BLUE POWER BATTERY CHARGER IP65



**Blue Power Charger
24V 3A IP65**

Completely encapsulated: waterproof, shockproof and ignition protected

Water, oil or dirt will not damage the Blue Power charger. The casing is made of cast aluminium and the electronics are moulded in resin.

Protected against overheating

Can be used in a hot environment such as a machine room. Output current will reduce as temperature increases up to 60°C, but the Blue Power charger will not fail.

Automatic three stage charging

Once the absorption voltage has been reached, the Blue Power charger will switch to float charge 2 hours after the charge current has reduced to a low break point current (see specifications), or after a 20 hour absorption period. The battery is therefore effectively protected against overcharging and can remain permanently connected to the charger. The charger will automatically reset and start a new charge cycle after interruption of the AC supply or after reduction of the output voltage to 12V resp. 24V due to a DC load.

Two LED's for status indication

Yellow LED: battery being charged

Yellow LED and Green LED: absorption charge

Green LED: float charge, the battery is charged

Learn more about batteries and battery charging

To learn more about batteries and charging batteries, please refer to our book 'Energy Unlimited' (available free of charge from Victron Energy and downloadable from www.victronenergy.com).



**Blue Power Charger
24V 12A IP65**

Blue Power charger Waterproof	12/7	12/17	24/3	24/12
Input voltage range (V AC)	200-265			
Frequency (Hz)	45-65			
Charge voltage 'absorption' (V DC)	14,4	14,4	28,8	28,8
Charge voltage 'float' (V DC)	13,7	13,7	27,4	27,4
Charge current (A)	7	17	3	12
Charge characteristic	3 stage with max. 18 hours absorption time			
Minimum battery capacity (Ah)	15	35	6	24
Breakpoint current (A)	0,7	1,7	0,3	1,2
Can be used as power supply	√	√	√	√
Protection (1)	a,b,c,			
Operating temp. range	-20 to +60°C (full rated output up to 40°C)			
Humidity	Up to 100 %			
ENCLOSURE				
Material & Colour	aluminium (blue RAL 5012)			
Battery-connection	Black and red cable of 1,5 meter			
230 V AC-connection (2)	Cable of 1,5 meter with CEE 7/7 or AS/NZS 3112 plug			
Protection category	IP 65			
Weight (kg)	1,1	1,4	1,1	1,4
Dimensions (h x w x d in mm)	43 x 80 x 155	47 x 99 x 193	43 x 80 x 155	47 x 99 x 193
STANDARDS				
Safety	EN 60335-1, EN 60335-2-29			
Emission Immunity	EN 55014-1, EN 61000-6-3, EN 61000-3-2			
Automotive Directive	EN 55014-2, EN 61000-6-1, EN 61000-6-2, EN 61000-3-3			
1) Protection key:		2) Other plug types on request		
a) Battery reverse polarity (fuse in battery cable)				
b) Output short circuit				
c) Over temperature				

BLUE POWER BATTERY CHARGER IP67 180 - 265VAC



**Blue Power Charger
IP67 12/25**

Completely encapsulated: waterproof, shockproof and ignition protected

Water, oil or dirt will not damage the Blue Power IP67 charger. The casing is made of cast aluminium and the electronics are moulded in resin.

Start interrupt

The models with suffix (1+Si) feature a second current limited output which is always powered as long as 180 – 265 VAC is present on the input. This output can for example be used to prevent starting of a vehicle before unplugging the battery charger (start interrupt function).

The highest efficiency ever!

Setting a new industry standard: with 92% efficiency or better, these chargers waste **three to four times less heat**.

And once the battery is fully charged, power consumption reduces to less than a Watt, some **five to ten times better** than the industry standard.

Adaptive 4-stage charge algorithm: bulk – absorption – float – storage

The Blue Power charger features a microprocessor controlled 'adaptive' battery management. The 'adaptive' feature will automatically optimise the charging process relative to the way the battery is being used.

Less maintenance and aging when the battery is not in use: the Storage Mode

The storage mode kicks in whenever the battery has not been subjected to discharge during 24 hours. In the storage mode float voltage is reduced to 2,2 V/cell (13,2 V for a 12 V battery) to minimise gassing and corrosion of the positive plates. Once a week the voltage is raised back to the absorption level to 'equalize' the battery. This feature prevents stratification of the electrolyte and sulphation, a major cause of early battery failure.

Protected against overheating

Can be used in a hot environment such as a machine room. Output current will reduce as temperature increases up to 60°C, but the charger will not fail.

Two LED's for status indication

Yellow LED: battery being charged

Yellow LED and Green LED: absorption charge

Green LED: float charge, the battery is charged

Blue Power charger Waterproof	12/17	12/25	24/8	24/12
Input voltage range and frequency	180-265 VAC 45-65 Hz			
Efficiency	94%	92%	95%	93%
No load power consumption	0.5W	0.5W	0.5W	0.5W
Charge voltage 'absorption' (V DC)	14,4	14,4	28,8	28,8
Charge voltage 'float' (V DC)	13,7	13,7	27,4	27,4
Charge voltage 'storage' (V DC)	13,2	13,2	26,4	26,4
Charge current (A)	17	25	8	12
Charge algorithm	4-stage adaptive			
Can be used as power supply	yes			
Protection	Battery reverse polarity (fuse)	Output short circuit	Over temperature	
Operating temp. range	-20 to +60°C (full rated output up to 40°C)			
Humidity	Up to 100 %			
Start interrupt option (Si)	Short circuit proof, current limit 0,5 A Output voltage: max one volt lower than main output			
ENCLOSURE				
Material & Colour	aluminium (blue RAL 5012)			
Battery-connection	Black and red cable of 1,5 meter			
230 V AC-connection	Cable of 1,5 meter with CEE 7/7 plug			
Protection category	IP67			
Weight (kg)	2,4			
Dimensions (h x w x d in mm)	99 x 219 x 65			
STANDARDS				
Safety	EN 60335-1, EN 60335-2-29			
Emission Immunity	EN 55014-1, EN 61000-6-3, EN 61000-3-2			
Automotive Directive	EN 55014-2, EN 61000-6-1, EN 61000-6-2, EN 61000-3-3			



Blue Power Charger IP65	12 V 7/10/15 A	24 V 5/8 A
Input voltage range	180-265 VAC	
Efficiency	94%	95%
Standby power consumption	0,5 W	
Charge voltage 'absorption'	Normal: 14,4 V High: 14,6 V Li-ion: 14,2 V	Normal: 28,8 V High: 29,2 V Li-ion: 28,4 V
Charge voltage 'float'	Normal: 13,8 V High: 13,8 V Li-ion: 13,5 V	Normal: 27,6 V High: 27,6 V Li-ion: 27,0 V
Charge voltage 'storage'	Normal: 13,2 V High: 13,2 V Li-ion: 13,5 V	Normal: 26,4 V High: 26,4 V Li-ion: 27,0 V
Charge current	7 / 10 / 15 A	5 / 8 A
Minimum battery capacity	24 / 30 / 45 Ah	16 / 24 Ah
Temperature compensation (lead-acid batteries only)	16 mV/°C	32 mV/°C
Can be used as power supply	Yes	
Back current drain	0,7 Ah/month (1 mA)	
Protection	Reverse polarity Output short circuit Over temperature	
Operating temp. range	-20 to +50°C (full rated output up to 30°C)	
Humidity (non condensing)	Max 95 %	
ENCLOSURE		
Battery-connection	Black and red cable of 1,5 meter	
230 V AC-connection	Cable of 1,5 meter with CEE 7/7, BS 1363 plug (UK) or AS/NZS 3112 plug	
Protection category	IP65 (splash and dust proof)	
Weight	0,9 kg	0,9 kg
Dimensions (h x w x d)	12/7: 47x95x190mm 0ther: 60x105x190mm	24/5: 47x95x190mm 24/8: 60x105x190mm
STANDARDS		
Safety	EN 60335-1, EN 60335-2-29	
Emission	EN 55014-1, EN 61000-6-3, EN 61000-3-2	
Immunity	EN 55014-2, EN 61000-6-1, EN 61000-6-2, EN 61000-3-3	
 victron energy <small>B L U E P O W E R</small>		
www.victronenergy.com Customer support: service@victronenergy.com		

blue power charger

IP65

The professional's choice

5
YEAR
WARRANTY



Energy. Anytime. Anywhere.

- **The highest efficiency ever!**
- Seven step smart charge algorithm
- Water resistant
- Automatic compensation for high or low temperature
- Fully discharged "dead" battery recovery function
- Several other battery life enhancing features
- Power supply function
- **Li-ion** battery mode



victron energy
BLUE POWER

Battery size Ah	Model		
	12 / 7 24 / 5	12 / 10 24 / 8	12 / 15
20 - 50	●	●	●
50 - 70	●	●	●
70 - 90	●	●	●
90 - 150	●	●	●

Quick selection guide

- Recommended
- Ok
- Not recommended

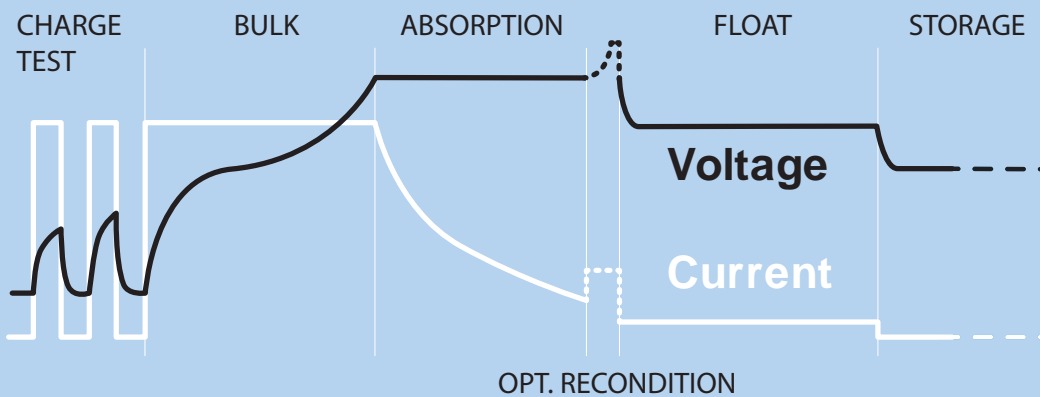

Reconditioning

A lead-acid battery that has been insufficiently charged or has been left discharged during days or weeks will deteriorate due to sulfation. If caught in time, sulfation can sometimes be partially reversed by charging the battery with low current up to a higher voltage.

Recovery function for fully discharged batteries

Most reverse polarity protected chargers will not recognize, and therefore not recharge a battery which has been discharged to zero or nearly zero Volts. The **Blue Power Charger** however will attempt to recharge a fully discharged battery with low current and resume normal charging once sufficient voltage has developed across the battery terminals.



Ultra high efficiency “green” battery charger

With up to 95% efficiency, these chargers generate up to four times less heat when compared to the industry standard. And once the battery is fully charged, power consumption reduces to 0,5 Watt, some five to ten times better than the industry standard.

Durable, safe and silent

- Low thermal stress on the electronic components.
- Protection against ingress of dust, water and chemicals.
- Protection against overheating: the output current will reduce as temperature increases up to 60°C, but the charger will not fail.
- The chargers are totally silent: no cooling fan or any other moving parts.

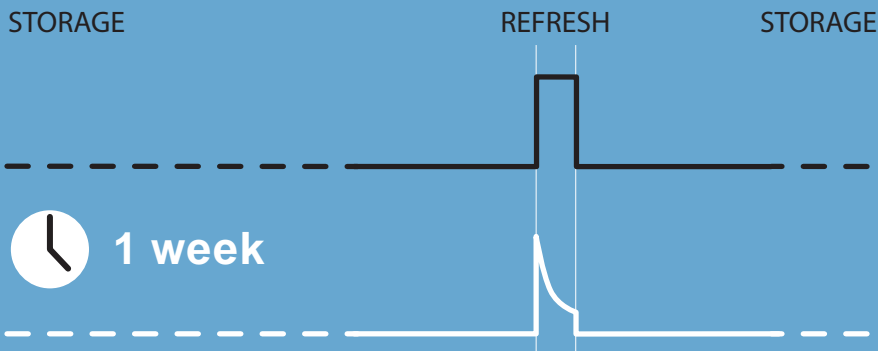

Storage mode: less corrosion of the positive plates

Even the lower float charge voltage that follows the absorption period will cause grid corrosion. It is therefore essential to reduce the charge voltage even further when the battery remains connected to the charger during more than 48 hours.

Temperature compensated charging

The optimal charge voltage of a lead-acid battery varies inversely with temperature. **The Blue Power IP65 Charger** measures ambient temperature during the test phase and compensates for temperature during the charge process. The temperature is measured again when the charger is in low current mode during float or storage. Special settings for a cold or hot environment are therefore not needed.

Li-ion battery mode

The **Blue Power Charger** uses a specific charging algorithm for Li-ion (LiFePO₄) batteries, with automatic Li-ion under voltage protection reset



CENTAUR CHARGER 12/24V



**Centaur
Battery Charger 24 30**

Quality without compromise

Aluminium epoxy powder coated cases with drip shield and stainless steel fixings withstand the rigors of an adverse environment: heat, humidity and salt air. Circuit boards are protected with an acrylic coating for maximum corrosion resistance. Temperature sensors ensure that power components will always operate within specified limits, if needed by automatic reduction of output current under extreme environmental conditions.

Universal 90-265V AC input voltage range and also suitable for DC supply (AC-DC and DC-DC operation)

All models will operate without any adjustment needed over a 90 to 265 Volt input voltage range, whether 50 Hz or 60 Hz.

The chargers also accept a 90-400V DC supply.

Three outputs that each can supply the full output current

Three isolated outputs to simultaneously charge 3 battery banks. Each output is capable to supply the full rated current.

Three stage charging, with temperature compensation

The Centaur charges at bulk rate until the output has reduced to 70 % of the rated Amps, at which a 4 hour timer begins. After the timed period the charger switches to float rate. An internal temperature sensor is used to compensate the charge voltage with $-2 \text{ mV}/^{\circ}\text{C}$ ($-1 \text{ mV}/^{\circ}\text{F}$) per cell. A dip switch is available to select the optimum charge/float voltages for Flooded Lead-acid, Gel or AGM batteries.

Learn more about batteries and battery charging

To learn more about batteries and charging batteries (including the pro's and con's of multi bank charging and intelligent charging), please refer to our book 'Electricity on Board' (available free of charge from Victron Energy and downloadable from www.victronenergy.com).

Charge curve

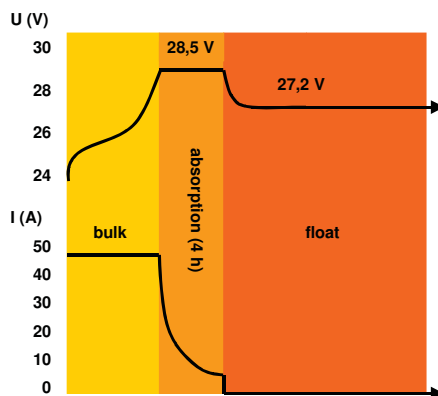

Application example

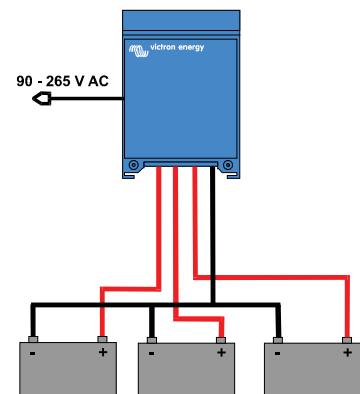

CENTAUR CHARGER 12/24V

Centaur Charger	12/20	12/30 24/16	12/40	12/50	12/60 24/30	12/80 24/40	12/100 24/60	24/80	12/200 24/100
Input voltage (V AC)	90 – 265								
Input voltage (V DC)	90 – 400								
Input frequency (Hz)	45 – 65								
Power factor	1								
Charge voltage 'absorption' (V DC)	14,3 / 28,5 (1)								
Charge voltage 'float' (V DC)	13,5 / 27,0 (1)								
Output banks	3								
Charge current (A) (2)	20	30 / 16	40	50	60 / 30	80 / 40	100 / 60	80	200 / 100
Total output ammeter	Yes								
Charge characteristic	IUoU (Three stage charging)								
Recommended battery capacity (Ah)	80 - 200	120 - 300 45 - 150	160 - 400	200 - 500	240 - 600 120 - 300	320 - 800 160 - 400	400 - 1000 240 - 600	320 - 800	800 - 2000 400 - 1000
Temperature sensor	Internal, - 2mV / °C (- 1 mV / °F) per cell								
Forced cooling	Yes, temperature and current controlled fan								
Protection	Output short circuit, over temperature								
Operating temp. range	- 20 to 60°C (0 - 140°F)								
Ignition protected	Yes								
Humidity (non condensing)	max 95%								

ENCLOSURE

Material & Colour	aluminium (blue RAL 5012)								
Battery-connection	M6 studs	M6 studs	M8 studs	M8 studs	M8 studs	M8 studs	M8 studs	M8 studs	M8 studs
AC-connection	screw-clamp 4 mm ² (AWG 6)								
Protection category	IP 21								
Weight kg (lbs)	3,8 (8.4)	3,8 (8.4)	5 (11)	5 (11)	5 (11)	12 (26)	12 (26)	16 (35)	16 (35)
Dimensions hwxwd in mm (hwxwd in inches)	355x215x110 (14.0x8.5x4.3)	355x215x110 (14.0x8.5x4.3)	426x239x135 (16.8x9.4x5.3)	426x239x135 (16.8x9.4x5.3)	426x239x135 (16.8x9.4x5.3)	505x255x130 (19.9x10.0x5.2)	505x255x130 (19.9x10.0x5.2)	505x255x230 (19.9x10.0x9.1)	505x255x230 (19.9x10.0x9.1)

STANDARDS

Safety	EN 60335-1, EN 60335-2-29, UL 1236								
Emission Immunity	EN 55014-1, EN 61000-3-2								
Automotive Directive	EN 55014-2, EN 61000-3-3								

1) Standard setting. Optimum charge/float voltages for Flooded Lead-acid, Gel-Cell or AGM batteries selectable by dip switch.

2) Up to 40 °C (100 °F) ambient. Output will reduce to approximately 80 % of nominal at 50 °C (120 °F) and 60 % of nominal at 60 °C (140°F).



BMV-600S Battery Monitor

The BMV- 600S Battery Monitor features an advanced microprocessor control system combined with high resolution measuring systems for battery voltage and charge/discharge current. Besides this, the software includes complex calculation algorithms, like Peukert's formula, to exactly determine the state of charge of the battery. The BMV – 600S selectively displays battery voltage, current, consumed Ah or time to go.



Battery Alarm

An excessively high or low battery voltage is indicated by an audible and visual alarm.

Installation made easy

1. Fasten the separate mounting plate (A) to the wall where you want to place the battery charger, and simply hook up the Centaur.
2. Secure the bottom of the backside (B) to the wall.



PHOENIX BATTERY CHARGER 12/24V



**Phoenix charger
12V 30A**



**Phoenix charger
24V 25A**

Adaptive 4-stage charge characteristic: bulk – absorption – float – storage

The Phoenix charger features a microprocessor controlled 'adaptive' battery management system that can be preset to suit different types of batteries. The 'adaptive' feature will automatically optimise the process relative to the way the battery is being used.

The right amount of charge: variable absorption time

When only shallow discharges occur (a yacht connected to shore power for example) the absorption time is kept short in order to prevent overcharging of the battery. After a deep discharge the absorption time is automatically increased to make sure that the battery is completely recharged.

Preventing damage due to excessive gassing: the BatterySafe mode (see fig. 2 below)

If, in order to quickly charge a battery, a high charge current in combination with a high absorption voltage has been chosen, the Phoenix charger will prevent damage due to excessive gassing by automatically limiting the rate of voltage increase once the gassing voltage has been reached (see the charge curve between 14,4 V and 15,0 V in fig. 2 below).

Less maintenance and aging when the battery is not in use: the Storage mode (see fig. 1 & 2 below)

The storage mode kicks in whenever the battery has not been subjected to discharge during 24 hours. In the storage mode float voltage is reduced to 2,2 V/cell (13,2 V for 12 V battery) to minimise gassing and corrosion of the positive plates. Once a week the voltage is raised back to the absorption level to 'equalize' the battery. This feature prevents stratification of the electrolyte and sulphation, a major cause of early battery failure.

To increase battery life: temperature compensation

Every Phoenix charger comes with a battery temperature sensor. When connected, charge voltage will automatically decrease with increasing battery temperature. This feature is especially recommended for sealed batteries and/or when important fluctuations of battery temperature are expected.

Battery voltage sense

In order to compensate for voltage loss due to cable resistance, Phoenix chargers are provided with a voltage sense facility so that the battery always receives the correct charge voltage.

Universal 90-265V AC input voltage range and also suitable for DC supply (AC-DC and DC-DC operation)

The chargers will accept a 90-400V DC supply.

Computer interface

Every Phoenix Charger is ready to communicate with a computer through its RS-485 data port. Together with our VEConfigure software, which can be downloaded free of charge from our [website www.victronenergy.com](http://www.victronenergy.com) and the data link MK1b (see accessories), all parameters of the chargers can be customised.

Learn more about batteries and battery charging

To learn more about batteries and charging batteries, please refer to our book 'Energy Unlimited' (available free of charge from Victron Energy and downloadable from www.victronenergy.com). For more information about adaptive charging please look under Technical Information on our website.

Charge curves: up to the gassing voltage (fig.1), and exceeding the gassing voltage (fig.2)

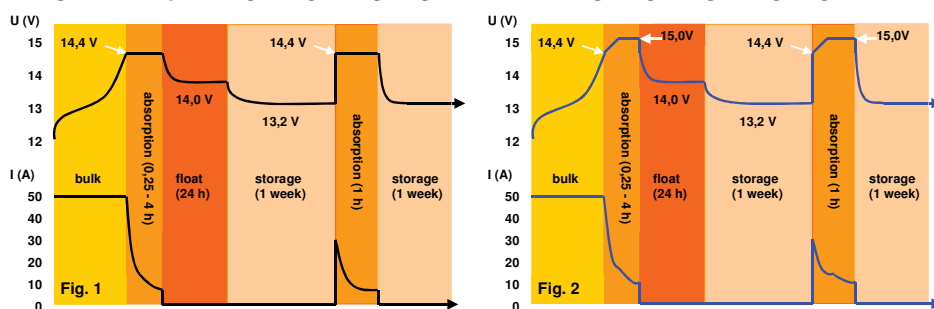

PHOENIX BATTERY CHARGER 12/24V

Phoenix Charger	12/30	12/50	24/16	24/25
Input voltage range (V AC)	90-265			
Input voltage range (V DC)	90-400			
Frequency (Hz)	45-65			
Power factor	1			
Charge voltage 'absorption' (V DC)	14,4	14,4	28,8	28,8
Charge voltage 'float' (V DC)	13,8	13,8	27,6	27,6
Storage mode (V DC)	13,2	13,2	26,4	26,4
Charge current house batt. (A) (2)	30	50	16	25
Charge current starter batt. (A)	4	4	4	4
Charge characteristic	4 stage adaptive			
Battery capacity (Ah)	100-400	200-800	100-200	100-400
Temperature sensor	√	√	√	√
Can be used as power supply	√	√	√	√
Forced cooling	√	√	√	√
Protection (1)	a,b,c,d			
Operating temp. range	-20 to 60°C (0 - 140°F)			
Humidity (non condensing)	max 95%			
ENCLOSURE				
Material & Colour	aluminium (blue RAL 5012)			
Battery-connection	M6 studs			
AC-connection	screw-clamp 4 mm ² (AWG 11)			
Protection category	IP 21			
Weight kg (lbs)	3,8 (8)			
Dimensions (hwxwd in mm and inches)	350x200x108 mm (13.8x7.9x4.3 inch)			
STANDARDS				
Safety	EN 60335-1, EN 60335-2-29			
Emission Immunity	EN 55014-1, EN 61000-3-2,			
Automotive Directive	EN 55014-2, EN 61000-3-3			
Vibration	IEC68-2-6:10-150Hz/1.0G			
1) Protection key: a) Output short circuit b) Battery reverse polarity detection	c) Battery voltage too high d) Temperature too high		2) Up to 40 °C (100 °F) ambient	



Battery Alarm

An excessively high or low battery voltage is indicated by an audible and visual alarm, and potential free contacts.



Phoenix Charger Control

The PCC panel provides remote control and monitoring of the charge process with LED indication of the charger status. In addition, the remote panel also offers output current adjustment that can be used to limit the output current and thus the power drawn from the AC supply. This is particularly useful when operating the charger from limited shore power or small gensets. The panel can also be used to change the battery charging parameters.

The brightness of the LED's is automatically reduced during night time. Connection to the charger is with a standard UTP – cable.



BMV 6005 Battery Monitor

The BMV 6005 Battery Monitor features an advanced microprocessor control system combined with high resolution measuring systems for battery voltage and charge/discharge current. Besides this, the software includes complex calculation algorithms, like Peukert's formula, to exactly determine the state of charge of the battery. The BMV 6005 selectively displays battery voltage, current, consumed Ah or time to go.

SKYLLA-I BATTERY CHARGER 24V

Li-Ion ready



Skylla-i 24/100 (3)



Skylla-i 24/100 (1+1)

Skylla-i (1+1): two outputs to charge 2 battery banks

The Skylla-i (1+1) features 2 isolated outputs. The second output, limited to approximately 4 A and with a slightly lower output voltage, is intended to top up a starter battery.

Skylla-i (3): three full current outputs to charge 3 battery banks

The Skylla-i (3) features 3 isolated outputs. All outputs can supply the full rated output current.

Rugged

Aluminium epoxy powder coated cases with drip shield and stainless steel fixings withstand the rigors of an adverse environment: heat, humidity and salt air.

Circuit boards are protected with an acrylic coating for maximum corrosion resistance.

Temperature sensors ensure that power components will always operate within specified limits, if needed by automatic reduction of output current under extreme environmental conditions.

Flexible

Next to a CAN bus (NMEA2000) interface, a rotary switch, DIP switches and potentiometers are available to adapt the charge algorithm to a particular battery and its conditions of use.

Please refer to the manual for a complete overview of the possibilities

Important features:

Synchronised parallel operation

Several chargers can be synchronised with the CAN bus interface. This is achieved by simply interconnecting the chargers with RJ45 UTP cables. Please see the manual for details.

The right amount of charge for a lead-acid battery: variable absorption time

When only shallow discharges occur the absorption time is kept short in order to prevent overcharging of the battery. After a deep discharge the absorption time is automatically increased to make sure that the battery is completely recharged.

Preventing damage due to excessive gassing: the BatterySafe mode

If, in order to quickly charge a battery, a high charge current in combination with a high absorption voltage has been chosen, the Skylla-i will prevent damage due to excessive gassing by automatically limiting the rate of voltage increase once the gassing voltage has been reached

Less maintenance and aging when the battery is not in use: the Storage mode

The storage mode kicks in whenever the battery has not been subjected to discharge during 24 hours. In the storage mode float voltage is reduced to 2,2 V/cell (26,4 V for 24 V battery) to minimise gassing and corrosion of the positive plates. Once a week the voltage is raised back to the absorption level to 'refresh' the battery. This feature prevents stratification of the electrolyte and sulphation, a major cause of early battery failure.

To increase battery life: temperature compensation

Every Skylla-i comes with a battery temperature sensor. When connected, charge voltage will automatically decrease with increasing battery temperature. This feature is especially recommended for sealed lead-acid batteries and/or when important fluctuations of battery temperature are expected.

Battery voltage sense

In order to compensate for voltage loss due to cable resistance, the Skylla-i is provided with a voltage sense facility so that the battery always receives the correct charge voltage.

Suitable for AC and DC supply (AC-DC and DC-DC operation)

The chargers also accept a DC supply.

Use as a power supply

As a result of the perfectly stabilized output voltage, the Skylla-i can be used as a power supply if batteries or large buffer capacitors are not available.

Li-Ion (LiFePO4) ready

Simple charger on-off control can be implemented by connecting a relay or open collector optocoupler output from a Li-Ion BMS to the remote control port of the charger. Alternatively complete control of voltage and current can be achieved by connecting to the galvanically isolated CAN bus port.

Learn more about batteries and battery charging

To learn more about batteries and charging batteries, please refer to our book 'Energy Unlimited' (available free of charge from Victron Energy and downloadable from www.victronenergy.com).

SKYLLA-I BATTERY CHARGER 24V

Skylla-i	24/80 (1+1)	24/80 (3)	24/100 (1+1)	24/100 (3)
Input voltage (VAC)	230 V			
Input voltage range (VAC)	185-265 V			
Input voltage range (VDC)	180-350 V			
Maximum AC input current @ 180 VAC	16 A		20 A	
Frequency (Hz)	45-65 Hz			
Power factor	0,98			
Charge voltage 'absorption' (VDC) (1)	28,8 V			
Charge voltage 'float' (VDC)	27,6 V			
Charge voltage 'storage' (VDC)	26,4 V			
Charge current (A) (2)	80 A	3 x 80 A (max total output: 80A)	100 A	3 x 100 A (max total output: 100A)
Charge current starter batt. (A)	4 A	n. a.	4	n. a.
Charge algorithm	7 stage adaptive			
Battery capacity (Ah)	400-800 Ah		500-1000 Ah	
Charge algorithm, Li-Ion	3 stage, with on-off control or CAN bus control			
Temperature sensor	Yes			
Can be used as power supply	Yes			
Remote on-off port	Yes (can be connected to a Li-Ion BMS)			
CAN bus communication port (VE.Can)	Two RJ45 connectors, NMEA2000 protocol, galvanically isolated			
Synchronised parallel operation	Yes, with VE.Can			
Alarm relay	DPST	AC rating: 240VAC/4A	DC rating: 4A up to 35VDC, 1A up to 60VDC	
Forced cooling	Yes			
Protection	Battery reverse polarity (fuse)		Output short circuit	Over temperature
Operating temp. range	-20 to 60°C (Full output current up to 40°C)			
Humidity (non condensing)	max 95%			
ENCLOSURE				
Material & Colour	aluminium (blue RAL 5012)			
Battery-connection	M8 bolts			
230 VAC-connection	screw-clamp 10mm ² (AWG 7)			
Protection category	IP 21			
Weight kg (lbs)	7 kg (16 lbs)			
Dimensions hxxxd in mm (hxxxd in inches)	405 x 250 x 150 mm (16.0 x 9.9 x 5.9 inch)			
STANDARDS				
Safety	EN 60335-1, EN 60335-2-29			
Emission	EN 55014-1, EN 61000-6-3, EN 61000-3-2			
Immunity	EN 55014-2, EN 61000-6-1, EN 61000-6-2, EN 61000-3-3			
1) Output voltage range 20-36V. Can be set with rotary switch or potentiometers.		2) Up to 40°C (100°F) ambient. Output will reduce to 80% at 50°C, and to 60% at 60°C.		



BMV 600S Battery Monitor

The BMV 600S Battery Monitor features an advanced microprocessor control system combined with high resolution measuring systems for battery voltage and charge/discharge current. The software includes complex calculation algorithms, like Peukert's formula, to exactly determine the state of charge of the battery. The BMV 600S selectively displays battery voltage, battery current, consumed Ah or time to go.



Skylla-i Control

The Skylla-i Control panel provides remote control and monitoring of the charge process with LED status indication. In addition, the remote panel also offers input current adjustment that can be used to limit the input current and thus the power drawn from the AC supply. This is particularly useful when operating the charger from limited shore power or small gensets. The panel can also be used to change several battery charging parameters. Several control panels can be connected to one charger or to a set of synchronised and parallel connected chargers.

SKYLLA-TG CHARGER 24/48V 230V



Skylla TG 24 50

Perfect chargers for any type of battery

Charge voltage can be precisely adjusted to suit any sealed or unsealed battery system. In particular, sealed maintenance free batteries must be charged correctly in order to ensure a long service life. Overvoltage will result in excessive gassing and venting of a sealed battery. The battery will dry out and fail.

Suitable for AC and DC supply (AC-DC and DC-DC operation)

Except for the 3 phase input models, the chargers also accept a DC supply.

Controlled charging

Every TG charger has a microprocessor, which accurately controls the charging in three steps. The charging process takes place in accordance with the IUoUo characteristic and charges more rapidly than other processes.

Use of TG chargers as a power supply

As a result of the perfectly stabilized output voltage, a TG charger can be used as a power supply if batteries or large buffer capacitors are not available.

Two outputs to charge 2 battery banks (24V models only)

The TG chargers feature 2 isolated outputs. The second output, limited to approximately 4 A and with a slightly lower output voltage, is intended to top up a starter battery.

To increase battery life: temperature compensation

Every Skylla TG charger comes with a battery temperature sensor. When connected, charge voltage will automatically decrease with increasing battery temperature. This feature is especially recommended for sealed batteries which otherwise might be overcharged and dry out due to venting.

Battery voltage sense

In order to compensate for voltage loss due to cable resistance, TG chargers are provided with a voltage sense facility so that the battery always receives the correct charge voltage.

Learn more about batteries and battery charging

To learn more about batteries and charging batteries, please refer to our book 'Energy Unlimited' (available free of charge from Victron Energy and downloadable from www.victronenergy.com).



Skylla TG 24 50 3 phase



Skylla TG 24 100

Charge curve

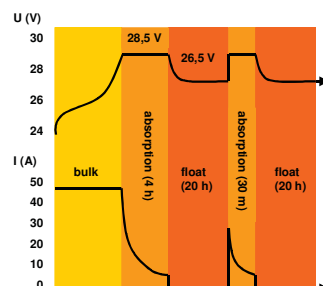

Application example

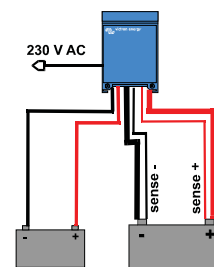

SKYLLA-TG CHARGER 24/48V 230V

Skylla	24/30 TG 24/50 TG	24/50 TG 3 phase	24/80 TG	24/100 TG	24/100 TG 3 phase	48/25 TG	48/50 TG
Input voltage (V AC)	230	3 x 400	230	230	3 x 400	230	230
Input voltage range (V AC)	185-264	320-450	185-264	185-264	320-450	185-264	185-264
Input voltage range (V DC)	180-400	n. a.	180-400	180-400	n. a.	180-400	180-400
Frequency (Hz)	45-65						
Power factor	1						
Charge voltage 'absorption' (V DC)	28,5	28,5	28,5	28,5	28,5	57	57
Charge voltage 'float' (V DC)	26,5	26,5	26,5	26,5	26,5	53	53
Charge current house batt. (A) (2)	30 / 50	50	80	100	100	25	50
Charge current starter batt. (A)	4	4	4	4	4	n. a.	n. a.
Charge characteristic	IUoUo (three step)						
Battery capacity (Ah)	150-500	250-500	400-800	500-1000	500-1000	125-250	250-500
Temperature sensor	√						
Can be used as power supply	√						
Remote alarm	Potential free contacts 60V / 1A (1x NO and 1x NC)						
Forced cooling	√						
Protection (1)	a,b,c,d						
Operating temp. range	-20 to 60°C (0 - 140°F)						
Humidity (non condensing)	max 95%						
ENCLOSURE							
Material & Colour	aluminium (blue RAL 5012)						
Battery-connection	M8 studs						
230 V AC-connection	screw-clamp 2,5 mm ² (AWG 6)						
Protection category	IP 21						
Weight kg (lbs)	5,5 (12.1)	13 (28)	10 (22)	10 (22)	23 (48)	5,5 (12.1)	10 (12.1)
Dimensions hxxwxd in mm (hxxwxd in inches)	365x250x147 (14.4x9.9x5.8)	365x250x257 (14.4x9.9x10.1)	365x250x257 (14.4x9.9x10.1)	365x250x257 (14.4x9.9x10.1)	515x260x265 (20x10.2x10.4)	365x250x147 (14.4x9.9x5.8)	365x250x257 (14.4x9.9x10.1)
STANDARDS							
Safety	EN 60335-1, EN 60335-2-29						
Emission	EN 55014-1, EN 61000-3-2						
Immunity	EN 55014-2, EN 61000-3-3						
1) Protection	c. Battery voltage too high						
a. Output short circuit	d. Temperature too high						
b. Battery reverse polarity detection							
2) Up to 40°C (100°F) ambient							



BMV 600S Battery Monitor

The BMV 600S Battery Monitor features an advanced microprocessor control system combined with high resolution measuring systems for battery voltage and charge/discharge current. Besides this, the software includes complex calculation algorithms, like Peukert's formula, to exactly determine the state of charge of the battery. The BMV 600S selectively displays battery voltage, current, consumed Ah or time to go.



Skylla Control

The Skylla Control allows you to alter the charge current and see the system status. Altering the charge current is useful if the shore power fuse is limited: the AC current drawn by the battery charger can be controlled by limiting the maximum output current, thereby preventing the shore power fuse from blowing.



Charger Switch

A remote on-off switch



Battery Alarm

An excessively high or low battery voltage is indicated by an audible and visual alarm.

SKYLLA-TG CHARGER 24V 90-265V GL APPROVED



Skylla Charger
24V 50A

Universal 90-265V AC input voltage range and also suitable for DC supply

All models will operate without any adjustment needed over a 90 to 265 Volt input voltage range, whether 50 Hz or 60 Hz.

The chargers will also accept a 90-400V DC supply.

Germanischer Lloyd approval

The Chargers have been approved by Germanischer Lloyd (GL) to environmental category C, EMC 1.

Category C applies to equipment protected from the weather.

EMC 1 applies to conducted and radiated emission limits for equipment installed on the bridge of a ship.

The approval to GL C, EMC1 implies that the Chargers also complies to IEC 60945-2002, category "protected" and "equipment installed on the bridge of a ship".

The GL certification applies to 185-265V AC supply.

Other features

- Microprocessor control
- Can be used as power supply
- Battery temperature sensor for temperature compensated charging
- Battery voltage sensing to compensate for voltage loss due to cable resistance

Other Skylla chargers

- Standard 185-265V AC models with additional output to charge a starter battery
- GMDSS models, with all required monitoring and alarm functions.

Learn more about batteries and battery charging

To learn more about batteries and charging batteries, please refer to our book 'Energy Unlimited' (available free of charge from Victron Energy and downloadable from www.victronenergy.com).

Charge curve

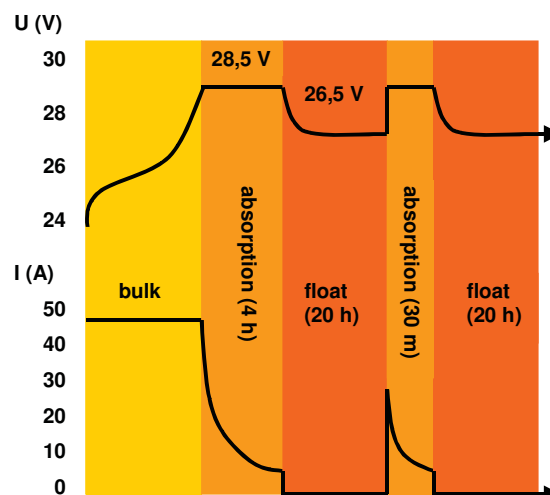

SKYLLA-TG CHARGER 24V 90-265V GL APPROVED

Skylia-TG	24/30 90-265 VAC	24/50 90-265 VAC	24/100-G 90-265 VAC
Input voltage (V AC)	230	230	230
Input voltage range (V AC)	90-265	90-265	90-265
Input voltage range (V DC)	90-400	90-400	90-400
Frequency (Hz)	45-65 Hz or DC		
Power factor	1		
Charge voltage 'absorption' (V DC)	28,5	28,5	28,5
Charge voltage 'float' (V DC)	26,5	26,5	26,5
Charge current house batt. (A) (2)	30 (limited to 22 A at 110V AC)	50	100
Charge current starter batt. (A)	4	4	4
Charge characteristic	IUoUo (three step)		
Battery capacity (Ah)	150-300	250-500	500-1000
Temperature sensor	√		
Can be used as power supply	√		
Remote alarm	Potential free contacts 60V / 1A (1x NO and 1x NC)		
Forced cooling	√		
Protection (1)	a,b,c,d		
Operating temp. range	-20 to 60°C (0 - 140°F)		
Humidity (non condensing)	max 95%		
ENCLOSURE			
Material & Colour	aluminium (blue RAL 5012)		
Battery-connection	M8 studs		
230 V AC-connection	screw-clamp 2,5 mm ² (AWG 6)		
Protection category	IP 21		
Weight kg (lbs)	5,5 (12.1)	5,5 (12.1)	10 (22)
Dimensions hxxwx d in mm (hxxwx d in inches)	365x250x147 (14.4x9.9x5.8)	365x250x147 (14.4x9.9x5.8)	365x250x257 (14.4x9.9x10.1)
STANDARDS			
Vibration	0,7g (IEC 60945)		
Safety	EN 60335-1, EN 60335-2-29, IEC 60945		
Emission	EN 55014-1, EN 61000-3-2, IEC 60945		
Immunity	EN 55014-2, EN 61000-3-3, IEC 60945		
Germanischer Lloyd	Certificate 54 758 – 08HH		
1) Protection key: a) Output short circuit b) Battery reverse polarity detection		c) Battery voltage too high d) Temperature too high	
		2) Up to 40°C (100°F) ambient	



BMV-600S Battery Monitor

The BMV – 600 Battery Monitor features an advanced microprocessor control system combined with high resolution measuring systems for battery voltage and charge/discharge current. Besides this, the software includes complex calculation algorithms, like Peukert's formula, to exactly determine the state of charge of the battery. The BMV – 600 selectively displays battery voltage, current, consumed Ah or time to go.



Skylia Control

The Skylia Control allows you to alter the charge current and see the system status. Altering the charge current is useful if the shore power fuse is limited: the AC current drawn by the battery charger can be controlled by limiting the maximum output current, thereby preventing the shore power fuse from blowing.

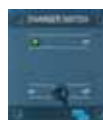

Charger Switch

A remote on-off switch



Battery Alarm

An excessively high or low battery voltage is indicated by an audible and visual alarm.

SKYLLA-TG 24/30 AND 24/50 GMDSS



**Skylla
TG 24 30 GMDSS**

GMDSS

The Global Maritime Distress & Safety System (GMDSS) was developed by the International Maritime Organisation (IMO) to improve maritime distress and safety communications.

Power supply

The Skylla TG has proven itself to be an excellent battery charger and power supply for GMDSS applications. However, when using a standard Skylla charger, additional equipment is needed to perform the monitoring and alarm functions required for GMDSS.

Installation made easy: the Skylla GMDSS

The Victron Skylla GMDSS charger has been designed to provide all required monitoring and alarm data. Both the battery and the GMDSS system are connected directly to the charger. Data and alarms are displayed on a digital panel (VE.Net GMDSS panel, to be ordered separately). A standard eight wire UTP cable connects the charger to the panel.

No adjustments needed

The whole system is 'click and go': the panels are pre-programmed for GMDSS functionality. A simple, intuitive menu allows changing of settings if required.

Battery time to go

The Skylla GMDSS charger has a built-in battery controller. The capacity of the battery is fully monitored so the panel can even indicate the 'time to go' in case of a power supply black out.

Perfect charger for any type of battery

Charge voltage can be precisely adjusted to suit any VRLA or flooded battery system.

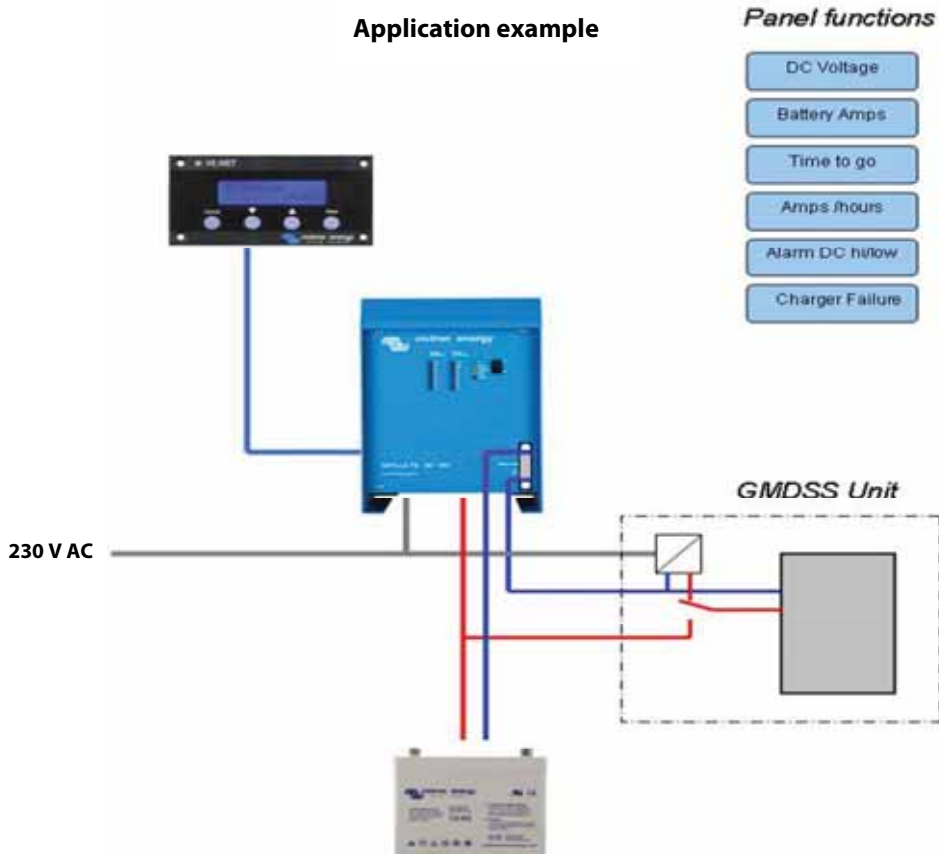

SKYLLA-TG 24/30 AND 24/50 GMDSS

Skylla-TG	24/30 GMDSS	24/50 GMDSS
Input voltage (V AC)	230	
Input voltage range (V AC)	90 - 265	
Frequency (Hz)	45-65	
Power factor	1	
Charge voltage 'absorption' (V DC)	28,5	
Charge voltage 'float' (V DC)	26,5	
Charge current (A)	30 (limited to 22 A at 110 V AC)	50
Charge characteristic	IUoUo (three step)	
Temperature sensor	√	
Can be used as power supply	√	
Forced cooling	√	
Protection (1)	a,b,c,d	
Operating temp. range	-20 to 60°C (0 - 140°F)	
Humidity (non condensing)	max 95%	
ENCLOSURE		
Material & Colour	aluminium (blue RAL 5012)	
Battery-connection	Two 1,5 m cables	
GMDSS connection	One 1,5 m cable (+ to be taken directly from the battery)	
230 V AC-connection	Three wire 2,5 mm ² (AWG 6) cable Length: 2 m	
Protection category	IP 21	
Weight kg (lbs)	6 (13)	
Dimensions hwxwd in mm (hwxwd in inches)	485x250x147 (19.1x9.9x5.8)	
ACCESORIES		
VE.Net GMDSS panel	To be ordered separately	
UTP cable	To be ordered separately	
STANDARDS		
Safety	EN 60335-1, EN 60335-2-29	
Emission Immunity	EN 55014-1, EN 61000-3-2	
Immunity	EN 55014-2, EN 61000-3-3	
Maritime Nav. & Radiocomm.	IEC 60945	
1)Protection key: a) output short circuit b) Battery reverse polarity detection	c) Battery voltage too high d) Temperature too high	2) Up to 40°C (100°F) ambient

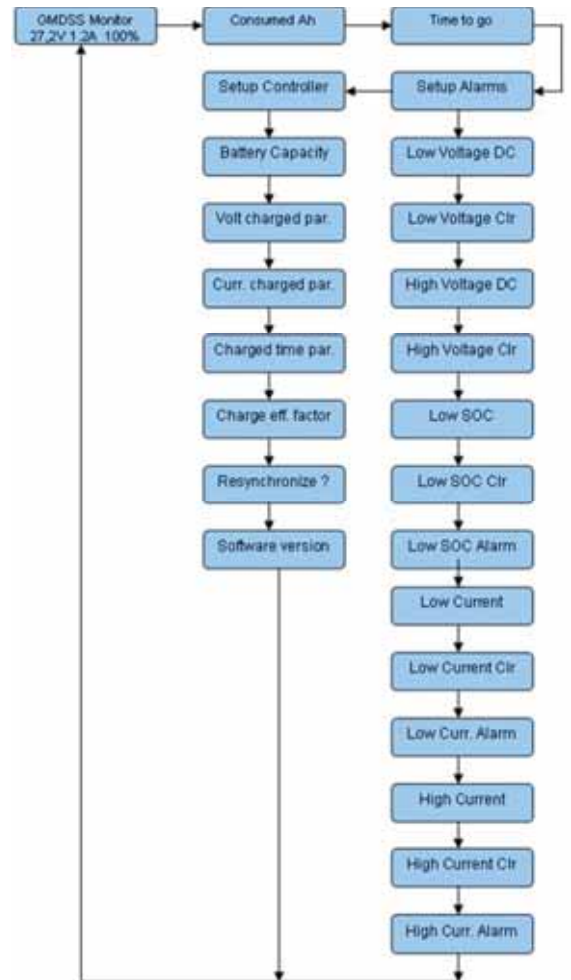

Remote panel GMDSS

The remote panel allows easy access to all important data. Alarm settings are pre-set but can also be re-programmed.

ISOLATION TRANSFORMERS



**Isolation Transformer
2000W**



**Isolation Transformer
3600W**

Safety and prevention of galvanic corrosion

The isolation transformer eliminates any electrical continuity between AC shore power and the boat. It is essential for safety and eliminates the need for galvanic isolators and polarity alarms.

Safety is taken for granted in case of a normal on-shore installation. A fuse will blow or a GFCI (Ground Fault Current Interrupter) will trip in case of a short circuit or current leakage to ground. Connecting the ground wire of the shore-side supply to the metal parts of the boat will result in galvanic corrosion (see below). Bringing only the live and neutral wire on board results in an unsafe situation because GFCI's will not work nor will a fuse blow in case of a short circuit to a metal part on the boat.

Galvanic corrosion occurs when two dissimilar metals in electrical contact are simultaneously exposed to an electrically conducting fluid. Seawater and, to a lesser extent, fresh water are such fluids. In general, the more active alloy of the couple corrodes preferentially while the less active (more noble) material is cathodically protected. The rate of galvanic corrosion is a function of several variables including area ratios, conductivity of the fluid, temperature, nature of the materials, etc.

It is a misunderstanding that galvanic corrosion occurs only in metal and aluminium hulls. In fact it can occur on any boat as soon as a metallic part (the shaft and propeller) is in contact with water. Galvanic corrosion will quickly dissolve your sacrificial anodes, and attack the shaft, propeller and other metal parts in contact with water as soon as the boat is connected to the shore-side supply. It might therefore be tempting not to connect the ground conductor: this is however extremely dangerous because GFCI's will not work nor will a fuse blow in case of a short circuit to a metal part on the boat.

The best solution to avoid galvanic corrosion and at the same time prevent any unsafe situation is to install an isolation transformer to connect to the shore-side supply.

The isolation transformer eliminates any electrical continuity between shore power and the boat. The shore power is fed to the primary side of the transformer and the ship is connected to the secondary. The isolation transformer completely isolates the boat from the shore ground. By connecting all metal parts to the neutral output on the secondary side of the transformer, a GFCI will trip or a fuse will blow in case of a short circuit.

Soft start is a standard feature of a Victron Energy isolation transformer. It will prevent the shore power fuse from blowing due to the inrush current of the transformer, which would otherwise occur.

It is also recommended, for optimal safety, to connect the secondary neutral of the transformer to ground when the boat is out of the water.

3600 Watt Auto 115/230V

This model will automatically switch to 115 V or 230 V supply, depending on input voltage.

Supply 88 V – 130V: switches to 115 V supply

Supply 185 – 250 V: switches to 230 V supply

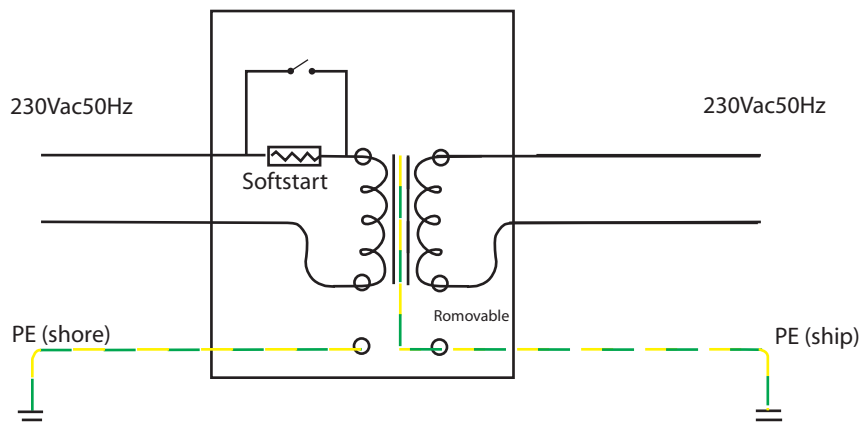

ISOLATION TRANSFORMERS

Isolation Transformers	2000 Watt (1)	3600 Watt (1)	3600 Watt Auto 115/230V (1)	7000 Watt
Input	115 or 230V	115 or 230V	115 / 230V Automatic 115/230V switching	230 V
Output	115 or 230V	115 or 230V	115 or 230V	230 V
Frequency	50/60Hz	50/60Hz	50/60Hz	50/60Hz
Rating	17 / 8,5 A	32 / 16 A	32 / 16 A	32 A
Soft start	Yes			
Transformer type	Toroidal (low noise, low weight)			
Input circuit breaker	yes			
ENCLOSURE				
Common Characteristics	Material: aluminium (blue RAL 5012)		Protection category: IP 21	
Weight	10 Kg	23 Kg	24 Kg	28 Kg
Dimensions (h x w x d), mm	375x214x110		362 x 258 x 218	
STANDARDS				
Safety	EN 60076			
1) Can be used as: 115 V to 115 V isolation transformer 115 V to 230 V isolation transformer	230 V to 230 V isolation transformer 230 V to 115 V isolation transformer			

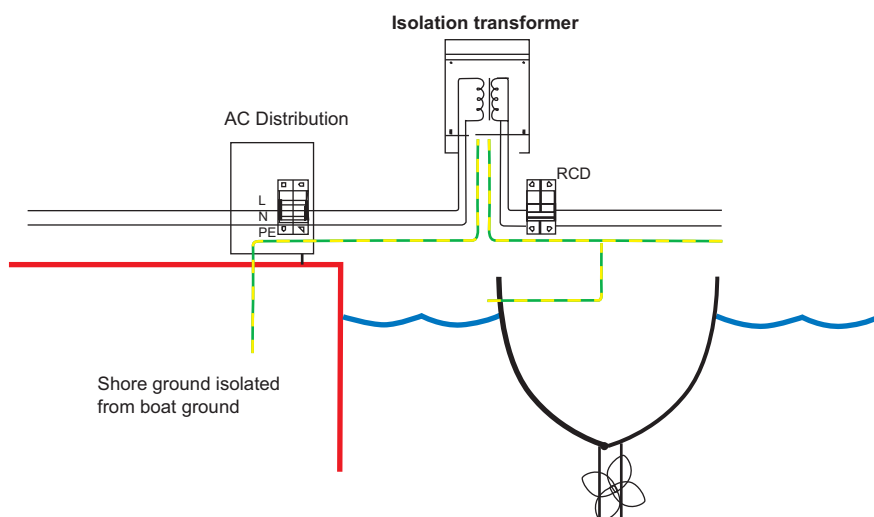
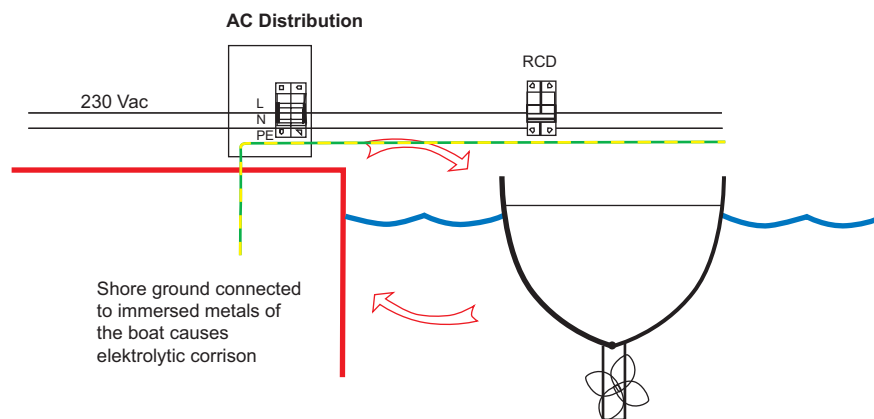

ORION DC/DC CONVERTERS



Orion 24/12-5



Orion 24/12-17

Remote on-off connector on the high power models (see table below)

The remote on-off eliminates the need for a high current switch in the input wiring. The remote on-off can be operated with a low power switch or by the engine run/stop switch (see manual).

All models with adjustable output can also be used as a battery charger

For example to charge a 12 Volt starter or accessory battery in an otherwise 24 V system.

All models with adjustable output can be paralleled to increase output current

Up to five units can be connected in parallel.

The Orion 12/27,6-12: a 24 V battery charger (see page 2)

To charge a 24 V battery from a 12 V system.

The output voltage of this model can be adjusted with a potentiometer

A super wide input range buck-boost regulator: the Orion 7-35/12-3 (see page 2)

The Orion 7-35/12-3 is an isolated converter with a very wide input range, suitable for both 12 V and 24 V systems, and a fixed 12,6 V output.

Easy to install

Delivery includes four Insulated Fastons Female Crimp 6.3 mm (eight Fastons in case of the Orion 24/12-40).



Orion 24/12-25



Orion 24/12-40



Orion 24/12-70

Non isolated converters	Orion 24/12-5	Orion 24/12-12	Orion 24/12-17	Orion 24/12-25	Orion 24/12-40	Orion 24/12-70	Orion 12/24-8	Orion 12/24-10	Orion 12/24-20
Input voltage range (V)	18-35	18-35	18-35	18-35	18-35	18-35	9-18	9-18	9-18
Undervoltage shutdown (V)	-	14	14	14	14	14	8	8	8
Undervoltage restart (V)	-	18	18	18	18	18	10	10	10
Output voltage adjustable with potentiometer	no	no	no	yes	no	yes	no	yes	yes
Output voltage (V)	12	12	12	Adjustable 10-15V F set 13,2V	12	Adjustable 10-15V F set 13,2V	24	Adjustable 20-30V F set 26,4V	Adjustable 20-30V F set 26,4V
Efficiency (%)	92	95	94	96	95	92	95	95	93
Suitable to buffer-charge a battery	no	no	no	yes	no	yes	no	yes	yes
Can be connected in parallel	no	no	no	yes	no	yes	no	yes	yes
Continuous output current (A)	5	12	17	25	40	70	8	10	20
Max. Output current (A)	5	20	25	35	55	85	20	20	30
Fan assisted cooling (temp. controlled)	no	no	no	no	yes	yes	no	no	yes
Galvanic isolation	no	no	no	no	no	no	no	no	no
Off load current	< 5mA	< 7mA	< 7mA	< 15mA	< 20mA	< 20mA	< 10mA	< 15mA	< 30mA
Remote on-off	no	no	no	yes	yes	yes	no	no	yes
Operating temperature range (derate 3% per °C above 40°C)	-20 to +55°C	-20 to +55°C	-20 to +55°C	-20 to +55°C	-20 to +55°C	-20 to +55°C	-20 to +55°C	-20 to +55°C	-20 to +55°C
DC connection	Faston tabs 6.3 mm	Faston tabs 6.3 mm	Faston tabs 6.3 mm	Faston tabs 6.3 mm	Double Faston tabs 6.3 mm	M6 bolts	Faston tabs 6.3 mm	Faston tabs 6.3 mm	M6 bolts
Weight kg (lbs)	0,2 (0.40)	0,3 (0.65)	0,3 (0.65)	0,7 (1.55)	0,85 (1.9)	0,9 (2.0)	0,4 (0.8)	0,4 (0.9)	0,9 (2.0)
Dimensions hxxwxd in mm (hxxwxd in inches)	45x90x65 (1.8x3.5x2.6)	45x90x100 (1.8x3.5x3.9)	45x90x110 (1.8x3.5x3.9)	65x88x160 (2.6x3.5x6.3)	65x88x185 (2.6x3.5x7.3)	65x88x195 (2.6x3.5x7.7)	45x90x115 (1.8x3.5x4.5)	45x90x125 (1.8x3.5x4.5)	65x88x195 (2.6x3.5x7.7)
Standards: Safety Emission Immunity Automotive Directive	EN 60950 EN 61000-6-3, EN 55014-1 EN 61000-6-2, EN61000-6-1, EN 55014-2 EN 50498								

ORION DC/DC CONVERTERS

Isolated converters	Orion xx/yy-100W	Orion xx/yy-200W	Orion xx/yy-360W
Power rating (W)	100 (12,5V/8A or 24V/4A)	200 (12,5V/16A or 24V/8A)	360 (12,5V/30A or 24V/15A)
Galvanic isolation	yes	yes	yes
Temperature increase after 30 minutes at full load (°C)	25	30	30
Fan assisted cooling (temp. controlled)	no	yes	yes
Weight kg (lbs)	0,5 (1.1)	0,6 (1.3)	1,4 (3.1)
Dimensions hxxwx d in mm (hxxwx d in inches)	49 x 88 x 152 (1.9 x 3.5 x 6.0)	49 x 88 x 182 (1.9 x 3.5 x 7.2)	64 x 163 x 160 (2.5 x 6.4 x 6.3)
Input voltage (xx): 12 V (9 – 18 V) or 24 V (20 – 35 V) or 48 V (30 – 60 V) or 96 V (60 – 120 V) or 110V (60 – 140V)			
Output voltage (yy): 12,5 V, 24 V or 48V			

Isolated 24V battery charger: Orion 12/27,6-12
 Input 9 – 18 V, output 27,6 V, current limit 12 A, fan assisted cooling
 Output voltage adjustable with potentiometer
 Weight 1,4 kg (3.1 lbs), dimensions 64 x 163 x 160 mm (2.5 x 6.4 x 6.3 inch)

Isolated buck-boost regulator: Orion 7-35/12-3
 Input 7 – 35 V, output 12,6 V current limit 3 A, derate current linearly from 3 A at 18 V to 1,5 A at 7 V
 Weight 1,4 kg (3.1 lbs), dimensions 64 x 163 x 160 mm (2.5 x 6.4 x 6.3 inch)

Common Characteristics	
Output voltage stability	2 % (Orion 12/24-7 and Orion 12/24-10: + 0% / - 5%)
Output voltage tolerance	3 %
Output noise	< 50 mV rms
Off load current	< 25 mA (isolated converters)
Efficiency	Non isolated: appr. 92% Isolated: appr. 85%
Isolation	> 400 Vrms between input, output and case (isolated products only)
Operating temperature	- 20 to + 40°C (0 to 100°F). Derate linearly to 0 A at 70°C (160°F)
Humidity	Max 95% non condensing
Casework	Anodised aluminum
Connections	6.3 mm (2.5 inch) push-on flat blade connectors
Protection: Overcurrent Overheating Reverse polarity connection Overvoltage	Short circuit proof Reduction of output voltage Fuse and reverse connected diode across input Varistor (also protects against load dump)
Standards: Safety Emission Immunity Automotive Directive	EN 60950 EN 61000-6-3, EN 55014-1 EN 61000-6-2, EN61000-6-1, EN 55014-2 EN 50498



Orion isolated 100W



Orion isolated 360W

COLOR CONTROL GX



Color Control GX

The Color Control provides intuitive control and monitoring for all products connected to it. The list of Victron products that can be connected is endless: Inverters, Multi's, Quattro's, MPPT 150/70, BMV-600, BMV-700, Skylla-i, Lynx Ion and even more.

VRM Online Portal

Besides monitoring and controlling products on the Color Control GX, the information is also forwarded to our free remote monitoring website: the VRM Online Portal. To get an impression of the VRM Online Portal, visit <https://vrm.victronenergy.com/>, and try our demo. See also the kWh dashboard screenshot further down in this datasheet.

Future functionality

The Color Control has endless possibilities. To implement all our ideas and wishes will take years. There are therefore many features that are not yet available. Functions marked with 'Future function' will become available later on, as a firmware update. Firmware updates are free of charge, as with all Victron products. Updating the product is easy: the Color Control GX will update itself automatically, as long as it is connected to the internet. Manual updates can be done with a USB stick and microSD cards.

Supported products

- Multi's, including split-phase and three phase systems. Monitoring and control (on/off and current limiter). Changing Multi settings is not yet available.
- Quattro's, including split-phase and three phase systems. Same limitations as Multi's, and some Quattro specific features, such as seeing which input is currently active, are not yet available.
- BlueSolar MPPT 150/70. Current solar output is visible on the overview screen, and all parameters are logged to the VRM online portal. Note that the VRM App has a nice overview showing data of the BlueSolar MPPT 150/70 as well. When multiple BlueSolar MPPT 150/70's are used in parallel, the Color Control will show all information as one. See also our blog-post about [synchronizing multiple MPPT 150/70 solar chargers](#).
- BMV-600 family can be connected to the VE.Direct ports on the Color Control GX. Use the VE.Direct to BMV60xS cable for that. [See our pricelist](#).
- BMV-700 family can be connected directly to the VE.Direct ports on the Color Control GX. Use the VE.Direct Cable for this. [See our pricelist](#).
- BlueSolar MPPT Solar Chargers with a VE.Direct port (70/15, 75/15, 100/15, 75/50) can also be connected to the VE.Direct ports on the Color Control GX. Connecting multiple at the same time is possible. They will all appear as a separate Solar Charger in the device list.
- A USB GPS can be connected to the USB port. Location and speed will be visible on the display, and the data is sent to the VRM Portal for tracking purposes. The map on VRM will show the latest position. Implementation of more advanced racking features on the VRM Portal is expected in 2014-Q1.
- Lynx Ion BMS
- Lynx Shunt VE.Can

Note that there are more options for products which use the VE.Direct ports, such as BMV's and small MPPT's. They can also be connected through USB, useful when more than two products need to be connected. Use an off-the-shelf USB-hub, and the VE.Direct to USB interface, ASS030530000.



Other highlights

- When connected to the internet, the Color Control GX will update itself automatically as if there is a new software version available. It checks for an update every night at 02:00 UTC.
- Multiple languages: English, Chinese, German, Italian, Spanish, French, Swedish and Dutch.

Notes for existing VGR2 and VER users

- Opposite to the Victron Global Remote 2 (VGR2) and Victron Ethernet Remote (VER), the Color Control GX stores all data locally during network interruptions. As soon as the connection to the VRM Online Portal is restored, it will automatically send all backlogged data to the portal. Data can then be analyzed on <https://vrm.victronenergy.com>. This local storage feature can be useful for diagnostics and problem solving as well: leave it for a couple of days in an installation where there are problems, then take it back to the office and connect it to the internet.
- Remote VEConfigure is not yet supported by the Color Control GX. This functionality is expected in 2014 Q1, and it will include support for changing Assistants and their settings, which is not possible with the VGR2 and VER.
- The local website, as present on the VER, is not yet supported.
- The Color Control GX has no internal GPRS modem: you cannot insert a sim-card into the Color Control GX. Support for VGR and VER connected through USB is coming in 2014-Q1. And we are looking for a lower cost alternative as well. Note that you can always use an off-the-shelf GPRS or 3G router. See FAQ for data consumption.



COLOR CONTROL GX

Color Control GX			
Power supply voltage range	9 – 70V DC		
Current draw	12V DC	24V DC	48V DC
Switched off	0mA	0mA	0mA
Display off	140mA	tbm	tbm
Display at minimum intensity	160mA	tbm	tbm
Display at maximum intensity	245mA	tbm	tbm
Potential free contact	3A / 30V DC / 250V AC (Normally open)		
Data communication			
VE.Direct	2 separate VE.Direct ports – isolated		
VE.Can	2 paralleled RJ45 sockets – isolated		
VE.Bus	2 paralleled RJ45 sockets – isolated		
USB	2 USB Host ports – not isolated		
Ethernet	10/100/1000MB RJ45 socket – isolated except shield		
Other			
Outer dimensions (h x w x d)			
Operating temperature range	-20 to +50°C		

Overview - Multi with PV Inverter on output (Hub-2)

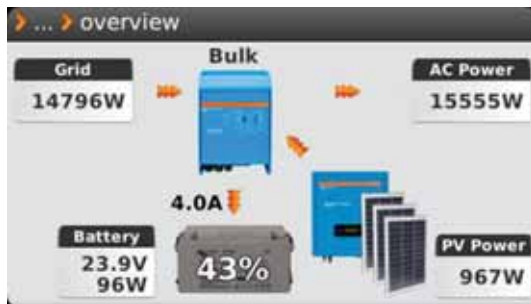

Main menu



Overview - Multi



Alarm notifications



Overview - Multi with MPPT 150/70



COLOR CONTROL GX

VRM Dashboard – Live feed



VRM Dashboard – Distribution of Solar Yield

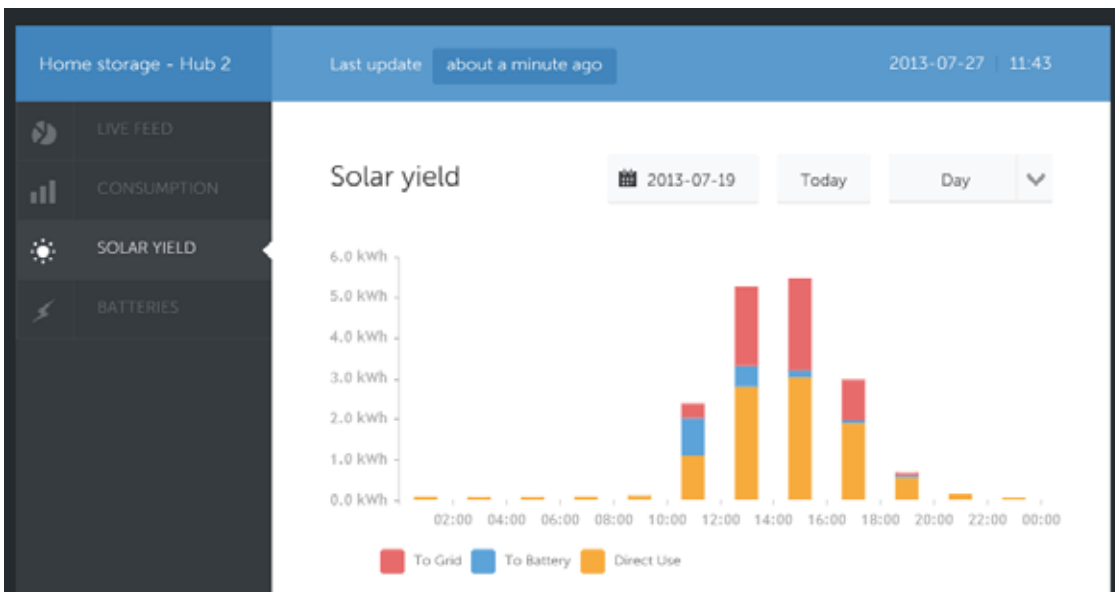

COLOR CONTROL GX

Color Control GX schematic diagram

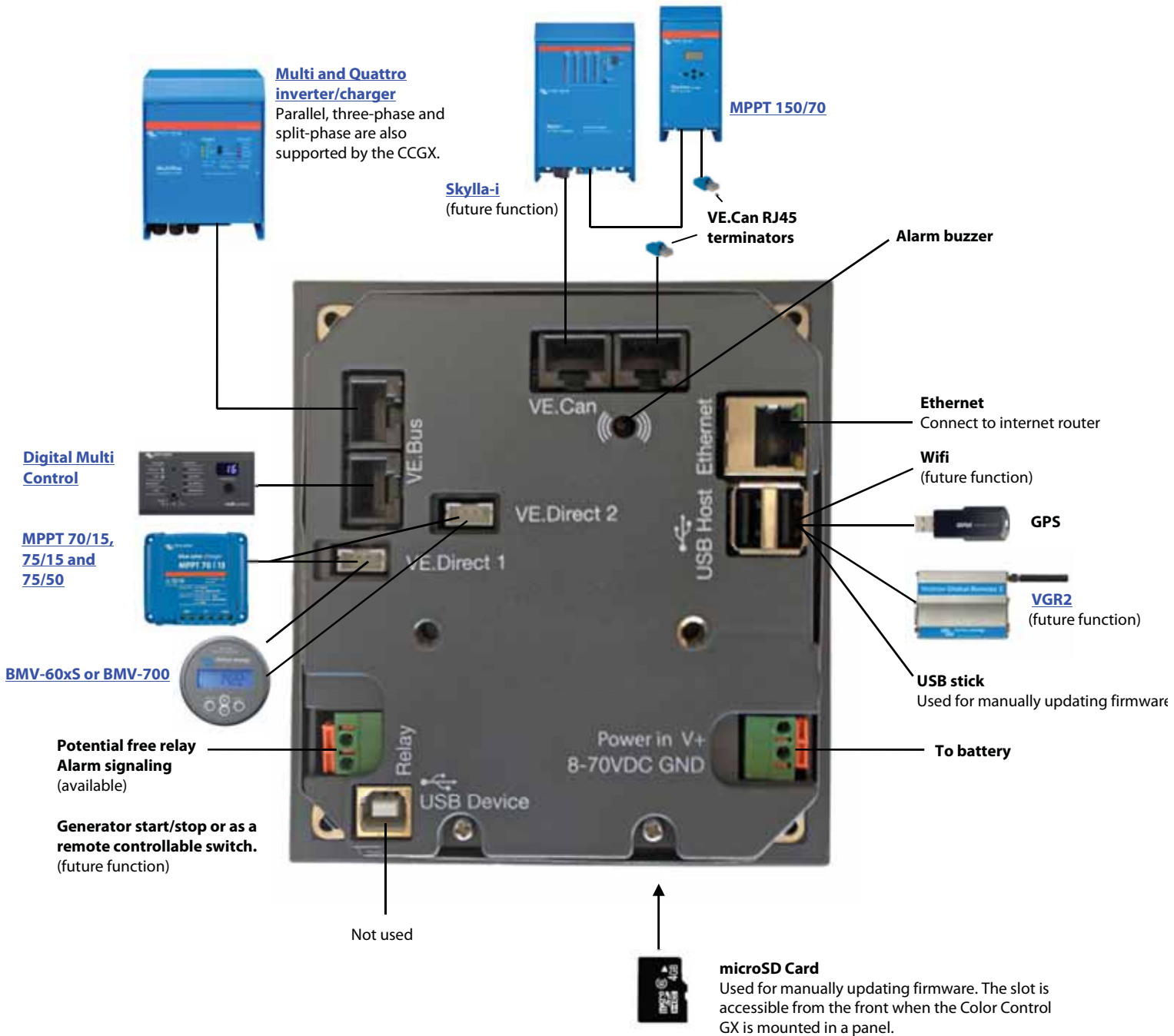

BLUE POWER PANEL



Blue Power Panel GX



Blue Power Panel 2

Blue Power Panel

The Blue Power Panel provides intuitive control for all devices connected to the VE.Net network. It can be used to view and configure the full range of settings on VE.Net devices. Furthermore, its fully customizable overview screens make it the ideal monitoring tool for your power system.

The BPP now features an integrated VE.Net to VE.Bus Converter (VVC). This allows you to combine the powerful control of the VE Configure software with the simple interface of the BPP, without requiring a computer or additional interface devices.

BPP2 and BPP GX

The Blue Power Panel 2 and the Blue Power Panel GX almost have the same features. The difference between the two models is the design and the mounting of the panel. The body of the GX panel is made of plastic, which makes the panel lighter and adds a modern look to the panel. An extra advantage of the GX panel is the easy mounting: the included mounting frame allows the user to mount the panel from either front or back side. Due to the mounting frame, the mounting holes will no longer be in sight.

Features

- Full control & monitoring of all connected VE.Net devices
- Integrated VE.Net to VE.Bus Converter (VVC)
- Real-time system status read-outs
- Customizable overview screens
- Special mounting frame for front or back side mounting (only GX-model)
- Easy to install

	Blue Power Panel GX	Blue Power Panel 2
Power supply voltage range	9 – 70 V DC	
Current draw @ 12 V (VVC disabled)		
Standby	<1mA	
Backlight off	55mA	
Backlight on	70mA	
Current draw @ 12 V (VVC enabled)		
Standby	<1mA	
Backlight off	70mA	
Backlight on	85mA	
Operating temp. range	-20 – +50°C	
Potential free contact	3A/30VDC/250V AC (Normally Open)	
ENCLOSURE		
Material & Colour	plastic	aluminium
Measurements front panel (w x h)	120 x 130 mm (Standard PROS2 Panel)	
Measurements body (w x h)	100 x 110 mm	
Weight	0.28 Kg	

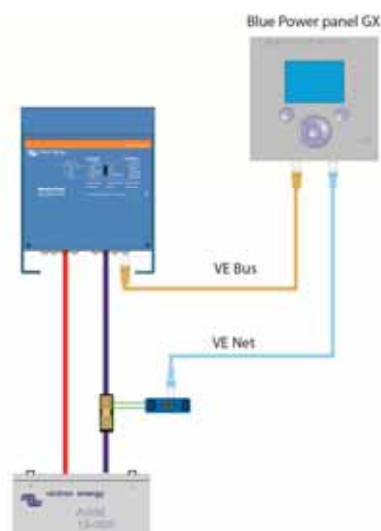

CYRIX-I 12/24V 120A AND 225A



Cyrix-i 12/24-120



Cyrix-i 12/24-225

Intelligent battery monitoring to prevent unwanted switching

Some battery combiners (also called voltage controlled relay, or split charge relay) will disconnect a battery in case of a short but high amperage load. A battery combiner also may fail to connect a large but discharged battery bank because the DC voltage immediately drops below the disengage value once the batteries are connected. The software of the Cyrix-i 12/24 does more than simply connect and disconnect based on battery voltage and with a fixed time delay. The Cyrix-i 12/24 looks at the general trend (voltage increasing or decreasing) and reverses a previous action only if the trend has reversed during a certain period of time. The time delay depends on the voltage deviation from the trend.

(for Battery Combiners with multiple engage/disengage profiles, please see the Cyrix-i 200A-400A)

12/24V auto ranging

The Cyrix-i 12/24 automatically detects system voltage.

No voltage loss

Cyrix battery combiners are an excellent replacement for diode isolators. The main feature is that there is virtually no voltage loss so that the output voltage of alternators or battery chargers does not need to be increased.

Prioritising the starter battery

In a typical setup the alternator is directly connected to the starter battery. The accessory battery, and possibly also a bow thruster and other batteries are each connected to the starter battery with Cyrix battery combiners. When a Cyrix senses that the starter battery has reached the connect voltage it will engage, to allow for parallel charging of the other batteries.

Bidirectional voltage sensing and power supply from both batteries

The Cyrix senses the voltage of both connected batteries. It will therefore also engage if for example the accessory battery is being charged by a battery charger.

The Cyrix-i 12/24 has a dual power supply. It will therefore also close if the voltage on one battery is too low to operate the Cyrix.

In order to prevent unexpected operation during installation or when one battery has been disconnected, the Cyrix-i 12/24 will not close if the voltage on one of the two battery connections is lower than 2V (12V battery) or 4V (24V battery).

Parallel connection in case of emergency (Start Assist)

The Cyrix can also be engaged with a push button (Cyrix remains engaged during 30 seconds) or a switch to connect batteries in parallel manually.

This is especially useful in case of emergency when the starter battery is discharged or damaged.

Cyrix battery combiner	Cyrix-i 12/24-120	Cyrix-i 12/24-225
Continuous current	120 A	225 A
Cranking rating (5 seconds)	180 A	500 A
Connect voltage	From 13V to 13,8V and 26 to 27,6V with intelligent trend detection	
Disconnect voltage	From 11V to 12,8V and 22 to 25,7V with intelligent trend detection	
Current consumption when open	<4 mA	
Start Assist	Yes (Cyrix remains engaged during 30 seconds)	
Protection category	IP54	
Weight kg (lbs)	0,11 (0,24)	0,66 (1,45)
Dimensions h x w x d in mm (h x w x d in inches)	46 x 46 x 80 (1.8 x 1.8 x 3.2)	100x90x100 (4.0x3.5x4.0)

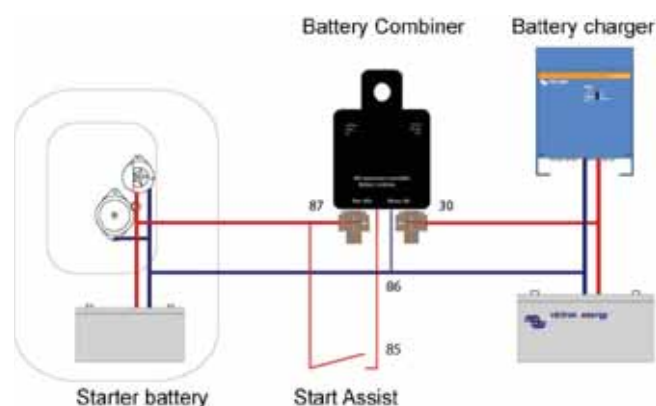

CYRIX-I 200A-400A 12/24V AND 24/48V



Cyrix-i 24/48V 400A

New: intelligent battery monitoring to prevent unwanted switching

Some battery combiners will disconnect a battery in case of a short but high amperage load. A battery combiner also may fail to connect a large but discharged battery bank because the DC voltage immediately drops below the disengage value once the batteries are connected.

The software of the Cyrix-i does more than simply connect and disconnect based on battery voltage and with a fixed time delay. The Cyrix-i looks at the general trend (voltage increasing or decreasing) and reverses a previous action only if the trend has reversed during a certain period of time. The time delay depends on the voltage deviation from the trend.

In addition, four switch timing profiles can be chosen (see back page).

12/24V and 24/48V auto ranging

The Cyrix-i automatically detects system voltage.

No voltage loss

Cyrix battery combiners are an excellent replacement for diode isolators. The main feature is that there is virtually no voltage loss so that the output voltage of alternators or battery chargers does not need to be increased.

Prioritising the starter battery

In a typical setup the alternator is directly connected to the starter battery. The accessory battery, and possibly also a bow thruster and other batteries are each connected to the starter battery with Cyrix battery combiners. When a Cyrix senses that the starter battery has reached the connect voltage it will engage, to allow for parallel charging of the other batteries.

Bidirectional voltage sensing and power supply from both batteries

The Cyrix senses the voltage of both connected batteries. It will therefore also engage if for example the accessory battery is being charged by a battery charger.

The Cyrix-i has a dual power supply. It will therefore also close if the voltage on one battery is too low to operate the Cyrix.

In order to prevent unexpected operation during installation or when one battery has been disconnected, the Cyrix-i will not close if the voltage on one of the two battery connections is lower than 2V (12V battery), or 4V (24V battery) or 8V (48V battery).

Parallel connection in case of emergency

The Cyrix can also be engaged with a push button (Cyrix remains engaged during 30s) or a switch to connect batteries in parallel manually.

This is especially useful in case of emergency when the starter battery is discharged or damaged.

Model	Cyrix-i 12/24-200 Cyrix-i 24/48-200	Cyrix-i 12/24-400 Cyrix-i 24/48-400
Continuous current	200A	400A
Peak current	1000A during 1 second	2000A during 1 second
Input voltage 12/24V model	8-36VDC	8-36VDC
Input voltage 24/48V model	16-72VDC	16-72VDC
Connect/disconnect profiles	See table	See table
Over voltage disconnect	16V / 32 / 64V	16V / 32 / 64V
Current consumption when open	4 mA	4 mA
Emergency start	Yes, 30s	Yes, 30s
Micro switch for remote monitoring	Yes	Yes
Status indication	Bicolor LED	Bicolor LED
Weight kg (lbs)	0,9 (2.0)	0,9 (2.0)
Dimensions h x w x d in mm (h x w x d in inches)	78 x 102 x 110 (3.1 x 4.0 x 4.4)	78 x 102 x 110 (3.1 x 4.0 x 4.4)

CYRIX-I 200A-400A 12/24V AND 24/48V

Profile 0			
Connect (V)*		Disconnect (V)*	
Less than 13V	Remains open	More than 12,8V	Remains closed
	Closes after		Opens after
13V	10 min	12,8V	10 min
13,2V	5 min	12,4V	5 min
13,4V	3 min	12,2V	1 min
13,6V	1 min	12V	4 sec
13,8V	4 sec	Less than 11V	Immediate

Profile 1			
Connect (V)*		Disconnect (V)*	
Less than 13,25V	Remains open	More than 12,75V	Remains closed
More than 13,25V	Closes after 30 sec	From 10,5V to 12,75V	Opens after 2 min
		Less than 10,5V	Immediate

Profile 2			
Connect (V)*		Disconnect (V)*	
Less than 13,2V	Remains open	More than 12,8V	Remains closed
More than 13,2V	Closes after 6 sec	From 10,5V to 12,8V	Opens after 30 sec
		Less than 10,5V	Immediate

Profile 3			
Connect (V)*		Disconnect (V)*	
Less than 13,25V	Remains open	More than 13,5V	Remains closed
	Closes after		Opens after
13V	10 min	12,8V	30 min
13,2V	5 min	12,4V	12 min
13,4V	3 min	12,2V	2 min
13,6V	1 min	12V	1 min
13,8V	4 sec	Less than 10,5V	Immediate

NOTES

- 1) After connecting 3 times, the minimum time to reconnect is 1 minute (to prevent "rattling")
- 2) The Cyrix will not connect if the voltage on one of the battery connections is less than 2V*. (to prevent unexpected switching during installation)
- 3) The Cyrix will always connect if the **start assist** is activated, as long as the voltage on one of the battery connections is sufficient to operate the Cyrix (approximately 10V*).

* Multiply voltage x2 for 24V systems and x4 for 48V systems

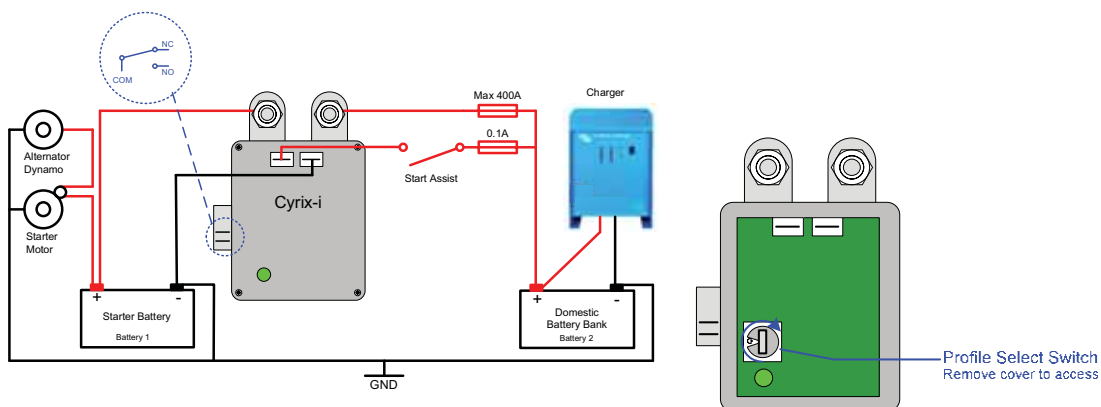

BMV700 PRECISION BATTERY MONITORING



BMV 700

Battery 'fuel gauge', time-to-go indicator, and much more

The remaining battery capacity depends on the ampere-hours consumed, discharge current, temperature and the age of the battery. Complex software algorithms are needed to take all these variables into account.

Next to the basic display options, such as voltage, current and ampere-hours consumed, the BMV-700 series also displays state of charge, time to go, and power consumption in Watts.

The BMV-702 features an additional input which can be programmed to measure the voltage (of a second battery), temperature or midpoint voltage (see below).

Easy to install

All electrical connections are to the quick connect PCB on the current shunt. The shunt connects to the monitor with a standard RJ12 telephone cable. Included: RJ 12 cable (10 m) and battery cable with fuse (2 m); no other components needed.

Also included are a separate front bezel for a square or round display appearance; a securing ring for the rear mounting and screws for the front mounting.

Easy to program

A quick install menu and a detailed setup menu with scrolling texts assists the user when going through the various settings. Please consult the manual for details.

New: midpoint voltage monitoring (BMV-702 only)

This feature which is often used in industry to monitor large and expensive battery banks, is now for the first time made available at a low cost, to monitor any battery bank.

A battery bank consists of a string of series connected cells. The midpoint voltage is the voltage halfway along the string. Ideally, the midpoint voltage would be exactly half of the total voltage. In practice, however, deviations will be seen, dependent on many factors such as a different state of charge for new batteries or cells, different temperatures, internal leakage currents, capacities and much more.

Large or increasing deviation of the midpoint voltage, points to improper battery care or a failed battery or cell. Corrective action following a midpoint voltage alarm can prevent severe damage to an expensive battery. Please consult the BMV manual for more information.

Standard features

- Battery voltage, current, power, ampere-hours consumed and state of charge
- Time to go at the current rate of discharge
- Programmable visual and audible alarm
- Programmable relay, to turn off non critical loads or to run a generator when needed.
- 500 Amp quick connect shunt and connection kit
- Shunt selection capability up to 10.000 Amps
- VE.Direct communication port
- Stores a wide range of historical events, which can be used to evaluate usage patterns and battery health
- Wide input voltage range: 9,5 – 95 V
- High current measurement resolution: 10 mA (0,01A)
- Low current consumption: 2,9 Ah per month (4 mA) @12V and 2,2 Ah per month (3mA) @ 24V

BMV-702 additional features

Additional input to measure voltage (of a second battery), temperature or midpoint voltage, and corresponding alarm and relay settings.

BMV 700HS: 60 to 385VDC voltage range

No prescaler needed. Note: suitable for systems with grounded minus only (battery monitor is not isolated from shunt).

Other battery monitoring options

- VE.Net Battery Controller
- High voltage VE.Net Battery Controller: 70 to 350VDC
- Lynx Shunt VE.Net
- Lynx Shunt VE.Can



BMV bezel square



BMV shunt 500A/50mV
With quick connect pcb



BMV 702 Black



BMV 700H

BMV700 PRECISION BATTERY MONITORING

Battery monitor	BMV 700	BMV 702 BMV 702 BLACK	BMV 700HS
Supply voltage range	6,5 - 95 VDC	6,5 - 95 VDC	60 - 385 VDC
Current draw, back light off	< 4 mA	< 4 mA	< 4 mA
Input voltage range, auxiliary battery	n.a.	6,5 - 95 VDC	n.a.
Battery capacity (Ah)	20 - 9999 Ah		
Operating temperature range	-20 +50°C (0 - 120°F)		
Measures voltage of second battery, or temperature, or midpoint	No	Yes	No
Temperature measurement range	-20 +50°C		n.a.
VE.Direct communication port	Yes	Yes	Yes
Relay	60V/1A normally open (function can be inverted)		
RESOLUTION & ACCURACY (with a 500 A shunt)			
Current	± 0,01 A		
Voltage	± 0,01 V		
Amp hours	± 0,1 Ah		
State of charge (0 - 100 %)	± 0,1 %		
Time to go	± 1 min		
Temperature (0 - 50°C or 30 - 120°F)	n. a.	± 1 °C/°F	n. a.
Accuracy of current measurement	± 0,4 %		
Accuracy of voltage measurement	± 0,3 %		
INSTALLATION & DIMENSIONS			
Installation	Flush mount		
Front	63 mm diameter		
Front bezel	69 x 69 mm (2.7 x 2.7 inch)		
Body diameter	52mm (2.0 inch)		
Body depth	31mm (1.2 inch)		
STANDARDS			
Safety	EN 60335-1		
Emission / Immunity	EN 55014-1 / EN 55014-2		
Automotive	ECE R10-4 / EN 50498		
ACCESSORIES			
Shunt (included)	500 A / 50 mV		
Cables (included)	10 meter 6 core UTP with RJ12 connectors, and cable with fuse for '+' connection		
Temperature sensor	Optional (ASS000100000)		



Victron Global Remote

The Global Remote is a modem which sends alarms, warnings and system status reports to cellular phones via text messages (SMS). It can also log data from Victron Battery Monitors, MultiPlus units, Quattros and Inverters to a website through a GPRS connection to the [VRM Portal](#). Access to this website is free of charge. VE.Direct to Global remote Interface cable needed (ASS030534000).



1000A/50mV and 2000A/50mV shunt

For ease of use with the BMV series: the quick connect PCB on the standard 500A/50mV shunt can also be mounted on these shunts.



Interface cables

- VE.Direct cables to connect a BMV 70x to the Color Control (ASS030530xxx)
- VE.Direct to USB interface (ASS030530000) to connect several BMV 70x to the Color Control or to a computer.
- VE.Direct to Global remote interface to connect a BMV 70x to a Global Remote. (ASS030534000)

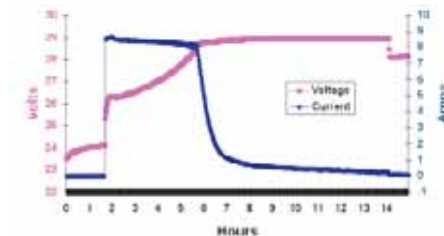

The PC application software **BMV-Reader** will show all current readings on a computer, including history data. It can also log the data to a CSV formatted file. It is available for free, and can be downloaded from our website at the [Support and downloads section](#). Connect the BMV to the computer with the VE.Direct to USB interface, ASS030530000.



Color Control

The powerful Linux computer, hidden behind the color display and buttons, collects data from all Victron equipment and shows it on the display. Besides communicating to Victron equipment, the Color Control communicates through NMEA2000, Ethernet and USB.

Data can be stored and analyzed on the VRM Portal. iPhone and Android apps are available for monitoring and control.

<https://vrm.victronenergy.com/>



A maximum of four BMVs can be connected directly to the Color Control.

Even more BMVs can be connected to a USB Hub for central monitoring.



ARGO DIODE BATTERY ISOLATORS



**Argo Diode Isolator
120-2AC**



**Argo Diode Isolator
140-3AC**

Diode battery isolators allow simultaneous charging of two or more batteries from one alternator, without connecting the batteries together. Discharging the accessory battery for example will not result in also discharging the starter battery.

The Argo battery isolators feature a low voltage drop thanks to the use of Schottky diodes: at low current the voltage drop is approximately 0,3 V and at the rated output approximately 0,45 V. All models are fitted with a compensation diode that can be used to slightly increase the output voltage of the alternator. This compensates for the voltage drop over the diodes in the isolator.

Please see our book 'Energy Unlimited' or ask for specialist advice when installing a diode isolator. Simply inserting the isolator in the cabling between the alternator and the batteries will slightly reduce charge voltage. The result can be that batteries are not charged to the full 100% and age prematurely.

Alternator energize input

Some alternators need DC voltage on the B+ output to start charging. Obviously, DC will be present when the alternator is directly connected to a battery. Inserting a Diode or FET splitter will however prevent any return voltage/current from the batteries to the B+, and the alternator will not start.

The new "AC" diode isolators feature a special current limited energize input that will power the B+ when the engine run/stop switch is closed.

Argo Diode Battery Isolator	80-25C	80-2AC	100-3AC	120-2AC	140-3AC	160-2AC	180-3AC
Maximum charge current (A)	80	80	100	120	140	160	180
Maximum alternator current (A)	80	80	100	120	140	160	180
Number of batteries	2	2	3	2	3	2	3
Alternator Energize Input	no	yes	yes	yes	yes	yes	yes
Connection	M6 Studs	M6 Studs	M6 Studs	M8 Studs	M8 Studs	M8 Studs	M8 Studs
Compensation diode and Energize connection	6,3 mm Faston	6,3 mm Faston	6,3 mm Faston	6,3 mm Faston	6,3 mm Faston	6,3 mm Faston	6,3 mm Faston
Weight kg (lbs)	0,5 (1.3)	0,6 (1.3)	0,8 (1.8)	0,8 (1.8)	1,1 (2.5)	1,1 (2.5)	1,5 (3.3)
Dimensions h x w x d in mm (h x w x d in inches)	60 x 120 x 75 (2.4 x 4.7 x 3.0)	60 x 120 x 90 (2.4 x 4.7 x 3.9)	60 x 120 x 115 (2.4 x 4.7 x 4.5)	60 x 120 x 115 (2.4 x 4.7 x 4.5)	60 x 120 x 150 (2.4 x 4.7 x 5.9)	60 x 120 x 150 (2.4 x 4.7 x 5.9)	60 x 120 x 200 (2.4 x 4.7 x 7.9)

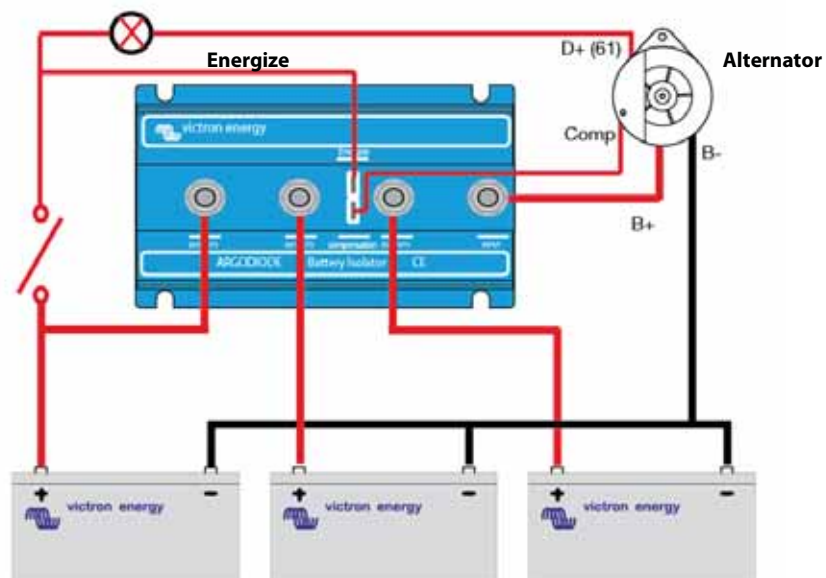

ARGO FET BATTERY ISOLATORS



**Argo FET 100-3
3bat 100A**

Similarly to diode battery isolators, FET isolators allow simultaneous charging of two or more batteries from one alternator (or a single output battery charger), without connecting the batteries together. Discharging the accessory battery for example will not result in also discharging the starter battery.

In contrast with diode battery isolators, FET isolators have virtually no voltage loss. Voltage drop is less than 0,02 Volt at low current and averages 0,1 Volt at higher currents.

When using ARGO FET Battery Isolators, there is no need to also increase the output voltage of the alternator. Care should taken however to keep cable lengths short and of sufficient cross section.

Example:

When a current of 100 A flows through a cable of 50 mm² cross section (AWG 0) and 10 m length (30 ft), the voltage drop over the cable will be 0,26 Volt. Similarly a current of 50 A through a cable of 10 mm² cross section (AWG 7) and 5 m length (15 ft) will result in a voltage drop of 0,35 Volt!

Alternator energize input

Some alternators need DC voltage on the B+ output to start charging. Obviously, DC will be present when the alternator is directly connected to a battery. Inserting a Diode or FET splitter will however prevent any return voltage/current from the batteries to the B+, and the alternator will not start.

The new Argofet isolators have a special current limited energize input that will power the B+ when the engine run/stop switch is closed.



**Argo FET 100-3
3bat 100A**

Argo FET Battery Isolator	Argofet 100-2	Argofet 100-3	Argofet 200-2	Argofet 200-3
Maximum charge current (A)	100	100	200	200
Maximum alternator current (A)	100	100	200	200
Number of batteries	2	3	2	3
Connection	M8 bolts	M8 bolts	M8 bolts	M8 bolts
Weight kg (lbs)	1,4 (3.1)	1,4 (3.1)	1,4 (3.1)	1,4 (3.1)
Dimensions h x w x d in mm (h x w x d in inches)	65 x 120 x 200 (2.6 x 4.7 x 7.9)	65 x 120 x 200 (2.6 x 4.7 x 7.9)	65 x 120 x 200 (2.6 x 4.7 x 7.9)	65 x 120 x 200 (2.6 x 4.7 x 7.9)

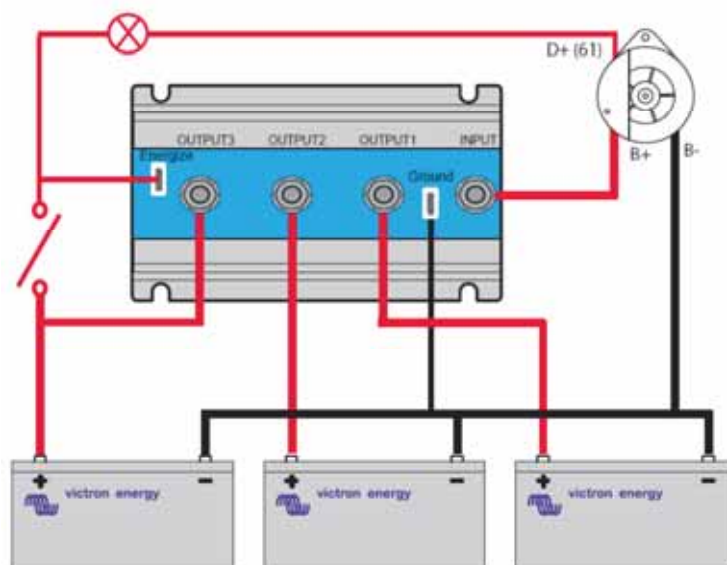

BLUESOLAR CHARGE CONTROLLERS - OVERVIEW



Feature highlights

- Ultra-fast Maximum Power Point Tracking (MPPT)
- Advanced Maximum Power Point Detection in case of partial shading conditions
- Load output on the small models
- BatteryLife: intelligent battery management by load shedding
- Automatic battery voltage recognition
- Flexible charge algorithm
- Over-temperature protection and power de-rating when temperature is high.

Color Control GX

All Victron Energy MPPT Charge Controllers are compatible with the Color Control GX: The Color Control GX provides intuitive control and monitoring for all products connected to it. The list of Victron products that can be connected is endless: Inverters, Multi's, Quattro's, MPPT 150/70, BMV-600 series, BMV-700 series, Skylla-i, Lynx Ion and even more.

VRM Online Portal

Besides monitoring and controlling products on the Color Control GX, the information is also forwarded to our free remote monitoring website: the VRM Online Portal. To get an impression of the VRM Online Portal, visit <https://vrm.victronenergy.com>, and use the 'Take a look inside' button. The portal is free of charge.

Related product: EasySolar

Minimal wiring and an all-in-one solution: the EasySolar takes power solutions one stage further, by combining an Ultra-fast BlueSolar charge controller (MPPT), an inverter/charger and AC distribution in one enclosure.

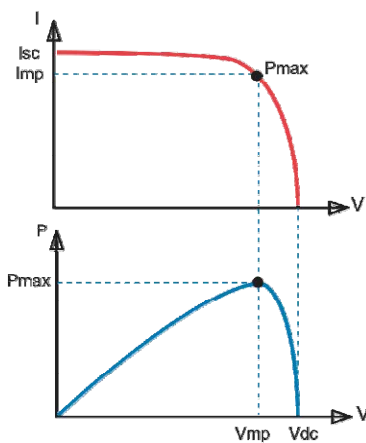

Maximum Power Point Tracking

Upper curve:

Output current (I) of a solar panel as function of output voltage (V).
 The maximum power point (MPP) is the point Pmax along the curve where the product $I \times V$ reaches its peak.

Lower curve:

Output power $P = I \times V$ as function of output voltage.
 When using a PWM (not MPPT) controller the output voltage of the solar panel will be nearly equal to the voltage of the battery, and will be lower than Vmp.

Model	Load output	Fan	Battery voltage	Display	Color Control GX	Com. port
75/15	Yes	No	12/24	No	Compatible	VE.Direct
100/15	Yes	No	12/24	No	Compatible	VE.Direct
100/30	No	No	12/24	No	Compatible	VE.Direct
75/50	No	No	12/24	No	Compatible	VE.Direct
100/50	No	No	12/24	No	Compatible	VE.Direct
150/35	No	No	12/24/36/48	No	Compatible	VE.Direct
150/70	No	No	12/24/36/48	Yes	Compatible	VE.Can
150/85	No	Yes	12/24/36/48	Yes	Compatible	VE.Can



BLUESOLAR CHARGE CONTROLLER MPPT 75/15 and MPPT 100/15



**Solar charge controller
MPPT 75/15**

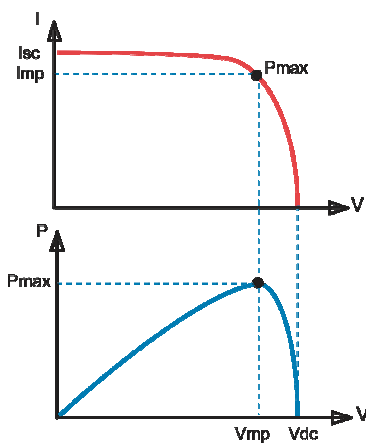

Maximum Power Point Tracking

Upper curve:

Output current (I) of a solar panel as function of output voltage (V).
The maximum power point (MPP) is the point Pmax along the curve where the product $I \times V$ reaches its peak.

Lower curve:

Output power $P = I \times V$ as function of output voltage.
When using a PWM (not MPPT) controller the output voltage of the solar panel will be nearly equal to the voltage of the battery, and will be lower than V_{mp} .

Ultra fast Maximum Power Point Tracking (MPPT)

Especially in case of a clouded sky, when light intensity is changing continuously, an ultra fast MPPT controller will improve energy harvest by up to 30% compared to PWM charge controllers and by up to 10% compared to slower MPPT controllers.

Load output

Over-discharge of the battery can be prevented by connecting all loads to the load output. The load output will disconnect the load when the battery has been discharged to a preset voltage. Alternatively, an intelligent battery management algorithm can be chosen: see BatteryLife.

The load output is short circuit proof.

Some loads (especially inverters) can best be connected directly to the battery, and the inverter remote control connected to the load output. A special interface cable may be needed, please see the manual.

BatteryLife: intelligent battery management

When a solar charge controller is not able to recharge the battery to its full capacity within one day, the result is often that the battery will be continually be cycled between a "partially charged" state and the "end of discharge" state. This mode of operation (no regular full recharge) will destroy a lead-acid battery within weeks or months.

The BatteryLife algorithm will monitor the state of charge of the battery and, if needed, day by day slightly increase the load disconnect level (i. e. disconnect the load earlier) until the harvested solar energy is sufficient to recharge the battery to nearly the full 100%. From that point onwards the load disconnect level will be modulated so that a nearly 100% recharge is achieved about once every week.

Resin encapsulated electronics

Protects the electronic components against the environment.

Automatic battery voltage recognition

The MPPT 75/15 will automatically adjust to a 12V or a 24V system.

BlueSolar charge controller	MPPT 75/15	MPPT 100/15
Battery voltage	12/24 V Auto Select	
Rated charge current	15 A	
Maximum PV power, 12V 1a,b)	200 W (MPPT range 15 V to 70 V resp. 95 V)	
Maximum PV power, 24V 1a,b)	400 W (MPPT range 30 V to 70 V resp. 95 V)	
Automatic load disconnect	Yes, maximum load 15 A	
Maximum PV open circuit voltage	75 V	100 V
Peak efficiency	98 %	
Self consumption	10 mA	
Charge voltage 'absorption'	14,4 V / 28,8 V	
Charge voltage 'float'	13,8 V / 27,6 V	
Charge algorithm	multi-stage adaptive	
Temperature compensation	-16 mV / °C resp. -32 mV / °C	
Continuous/peak load current	15A / 50A	
Low voltage load disconnect	11,1 V / 22,2 V or 11,8 V / 23,6 V or BatteryLife algorithm	
Low voltage load reconnect	13,1 V / 26,2 V or 14 V / 28 V or BatteryLife algorithm	
Protection	Battery reverse polarity (fuse) Output short circuit Over temperature	
Operating temperature	-30 to +60°C (full rated output up to 40°C)	
Humidity	100 %, non-condensing	
Data communication port	VE.Direct	
	See the data communication white paper on our website	
ENCLOSURE		
Colour	Blue (RAL 5012)	
Power terminals	6 mm ² / AWG10	
Protection category	IP65 (electronic components), IP22 (connection area)	
Weight	0,5 kg	
Dimensions (h x w x d)	100 x 113 x 40 mm	
1a) If more PV power is connected, the controller will limit input power to 200W resp. 400W		
1b) PV voltage must exceed $V_{bat} + 5V$ for the controller to start. Thereafter minimum PV voltage is $V_{bat} + 1V$		

BLUESOLAR CHARGE CONTROLLER MPPT 100/30



**Solar charge controller
MPPT 100/30**

Charge current up to 30 A and PV voltage up to 100 V

The BlueSolar 100/30-MPPT charge controller is able to charge a lower nominal-voltage battery from a higher nominal voltage PV array. The controller will automatically adjust to a 12 or 24V nominal battery voltage.

Ultra-fast Maximum Power Point Tracking (MPPT)

Especially in case of a cloudy sky, when light intensity is changing continuously, an ultra fast MPPT controller will improve energy harvest by up to 30% compared to PWM charge controllers and by up to 10% compared to slower MPPT controllers.

Advanced Maximum Power Point Detection in case of partial shading conditions

If partial shading occurs, two or more maximum power points may be present on the power-voltage curve.

Conventional MPPT's tend to lock to a local MPP, which may not be the optimum MPP.

The innovative BlueSolar algorithm will always maximize energy harvest by locking to the optimum MPP.

Outstanding conversion efficiency

No cooling fan. Maximum efficiency exceeds 98%. Full output current up to 40°C (104°F).

Flexible charge algorithm

Eight preprogrammed algorithms, selectable with a rotary switch (see manual for details)

Extensive electronic protection

Over-temperature protection and power derating when temperature is high.

PV short circuit and PV reverse polarity protection.

PV reverse current protection.

Internal temperature sensor

Compensates absorption and float charge voltages for temperature.

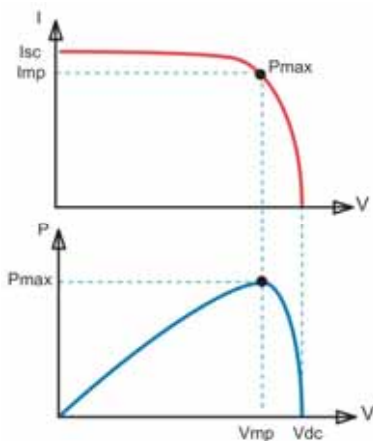

Maximum Power Point Tracking

Upper curve:

Output current (I) of a solar panel as function of output voltage (V).

The maximum power point (MPP) is the point Pmax along the curve where the product $I \times V$ reaches its peak.

Lower curve:

Output power $P = I \times V$ as function of output voltage.

When using a PWM (not MPPT) controller the output voltage of the solar panel will be nearly equal to the voltage of the battery, and will be lower than Vmp.

BlueSolar charge controller	MPPT 100/30
Battery voltage	12/24 V Auto Select
Maximum output current	30 A
Maximum PV power, 12V 1a,b)	440 W (MPPT range 15 V to 80 V)
Maximum PV power, 24V 1a,b)	880 W (MPPT range 30 V to 80 V)
Maximum PV open circuit voltage	100 V
Maximum efficiency	98 %
Self-consumption	10 mA
Charge voltage 'absorption'	Default setting: 14,4 V / 28,8 V
Charge voltage 'float'	Default setting: 13,8 V / 27,6 V
Charge algorithm	multi-stage adaptive
Temperature compensation	-16 mV / °C resp. -32 mV / °C
Protection	Battery reverse polarity (fuse) Output short circuit Over temperature
Operating temperature	-30 to +60°C (full rated output up to 40°C)
Humidity	95 %, non-condensing
Data communication port	VE.Direct See the data communication white paper on our website
ENCLOSURE	
Colour	Blue (RAL 5012)
Power terminals	13 mm ² / AWG6
Protection category	IP43 (electronic components), IP22 (connection area)
Weight	1,25 kg
Dimensions (h x w x d)	130 x 186 x 70 mm
1a) If more PV power is connected, the controller will limit input power to 440W resp. 700W	
1b) PV voltage must exceed Vbat + 5V for the controller to start. Thereafter minimum PV voltage is Vbat + 1V	

BLUESOLAR CHARGE CONTROLLERS MPPT 75/50 and MPPT 100/50



**Solar charge controller
MPPT 75/50**

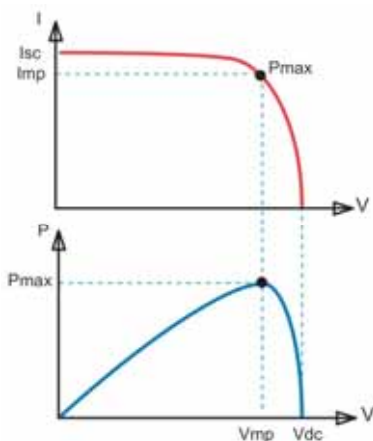

Maximum Power Point Tracking

Upper curve:

Output current (I) of a solar panel as function of output voltage (V).
 The maximum power point (MPP) is the point P_{max} along the curve where the product I x V reaches its peak.

Lower curve:

Output power $P = I \times V$ as function of output voltage.
 When using a PWM (not MPPT) controller the output voltage of the solar panel will be nearly equal to the voltage of the battery, and will be lower than V_{mp}.

Charge current up to 50 A and PV voltage up to 75 V, respectively 100 V

The BlueSolar charge controllers will charge a lower nominal-voltage battery with a higher nominal voltage PV array.

The controllers automatically adjust to 12 V or 24 V nominal battery voltage.

Ultra-fast Maximum Power Point Tracking (MPPT)

Especially in case of a clouded sky, when light intensity is changing continuously, an ultra fast MPPT controller will improve energy harvest by up to 30% compared to PWM charge controllers and by up to 10% compared to slower MPPT controllers.

Advanced Maximum Power Point Detection in case of partial shading conditions

If partial shading occurs, two or more maximum power points may be present on the power-voltage curve.

Conventional MPPT's tend to lock to a local MPP, which may not be the optimum MPP.

The innovative BlueSolar algorithm will always maximize energy harvest by locking to the optimum MPP.

Outstanding conversion efficiency

No cooling fan. Maximum efficiency exceeds 98%. Full output current up to 40°C (104°F).

Flexible charge algorithm

Eight preprogrammed algorithms, selectable with a rotary switch (see manual for details)

Extensive electronic protection

Over-temperature protection and power derating when temperature is high.

PV short circuit and PV reverse polarity protection.

PV reverse current protection.

Internal temperature sensor

Compensates absorption and float charge voltages for temperature.

BlueSolar charge controller	MPPT 75/50	MPPT 100/50
Battery voltage	12/24 V Auto Select	
Rated charge current	50 A	
Maximum PV power, 12V 1a,b)	700 W (MPPT range 15 V to 70 V resp. 95 V)	
Maximum PV power, 24V 1a,b)	1400 W (MPPT range 30 V to 70 V resp. 95 V)	
Maximum PV open circuit voltage	75 V	100 V
Maximum efficiency	98 %	
Self-consumption	10 mA	
Charge voltage 'absorption'	Default setting: 14,4 V / 28,8 V	
Charge voltage 'float'	Default setting: 13,8 V / 27,6 V	
Charge algorithm	multi-stage adaptive	
Temperature compensation	-16 mV / °C resp. -32 mV / °C	
Protection	Battery reverse polarity (fuse) PV reverse polarity Output short circuit Over temperature	
Operating temperature	-30 to +60°C (full rated output up to 40°C)	
Humidity	95 %, non-condensing	
Data communication port	VE.Direct See the data communication white paper on our website	
ENCLOSURE		
Colour	Blue (RAL 5012)	
Power terminals	13 mm ² / AWG6	
Protection category	IP43 (electronic components), IP22 (connection area)	
Weight	1,25 kg	
Dimensions (h x w x d)	130 x 186 x 70 mm	
1a) If more PV power is connected, the controller will limit input power to 700W resp. 1400W 1b) PV voltage must exceed V _{bat} + 5V for the controller to start. Thereafter minimum PV voltage is V _{bat} + 1V		

BLUESOLAR CHARGE CONTROLLER MPPT 150/35



Solar charge controller
MPPT 150/35

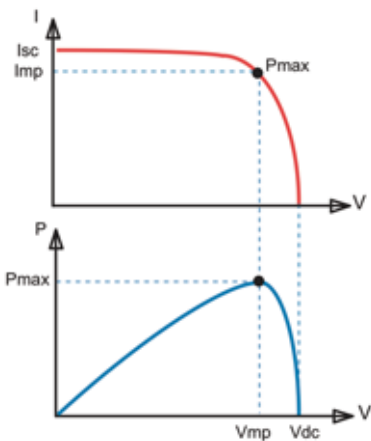

Maximum Power Point Tracking

Upper curve:

Output current (I) of a solar panel as function of output voltage (V).
The maximum power point (MPP) is the point Pmax along the curve where the product $I \times V$ reaches its peak.

Lower curve:

Output power $P = I \times V$ as function of output voltage.
When using a PWM (not MPPT) controller the output voltage of the solar panel will be nearly equal to the voltage of the battery, and will be lower than Vmp.

Charge current up to 35 A and PV voltage up to 150 V

The BlueSolar charge controller will charge a lower nominal-voltage battery with a higher nominal voltage PV array.

The controller will automatically adjust to 12 V, 24 V or 48 V nominal battery voltage. (software tool needed to select 36 V)

Ultra-fast Maximum Power Point Tracking (MPPT)

Especially in case of a cloudy sky, when light intensity is changing continuously, an ultra-fast MPPT controller will improve energy harvest by up to 30% compared to PWM charge controllers and by up to 10% compared to slower MPPT controllers.

Advanced Maximum Power Point Detection in case of partial shading conditions

If partial shading occurs, two or more maximum power points may be present on the power-voltage curve.

Conventional MPPT's tend to lock to a local MPP, which may not be the optimum MPP.

The innovative BlueSolar algorithm will always maximize energy harvest by locking to the optimum MPP.

Outstanding conversion efficiency

No cooling fan. Maximum efficiency exceeds 98%. Full output current up to 40°C (104°F).

Flexible charge algorithm

Eight preprogrammed algorithms, selectable with a rotary switch (see manual for details)

Extensive electronic protection

Over-temperature protection and power derating when temperature is high.

PV short circuit and PV reverse polarity protection.

PV reverse current protection.

Internal temperature sensor

Compensates absorption and float charge voltages for temperature.

BlueSolar charge controller	MPPT 150/35
Battery voltage	12 / 24 / 48 V Auto Select (software tool needed to select 36 V)
Rated charge current	35 A
Maximum PV power, 12V 1a,b)	12V: 500W / 24V: 1000W / 36V: 1500W / 48V: 2000W
Maximum PV open circuit voltage	150V absolute maximum coldest conditions 145V start-up and operating maximum
Maximum efficiency	98 %
Self-consumption	0,01 mA
Charge voltage 'absorption'	Default setting: 14,4 / 28,8 / 43,2 / 57,6 V
Charge voltage 'float'	Default setting: 13,8 / 27,6 / 41,4 / 55,2 V
Charge algorithm	multi-stage adaptive
Temperature compensation	-16 mV / °C resp. -32 mV / °C
Protection	Battery reverse polarity (fuse) PV reverse polarity Output short circuit Over temperature
Operating temperature	-30 to +60°C (full rated output up to 40°C)
Humidity	95 %, non-condensing
Data communication port	VE.Direct See the data communication white paper on our website
ENCLOSURE	
Colour	Blue (RAL 5012)
Power terminals	13 mm ² / AWG6
Protection category	IP43 (electronic components), IP22 (connection area)
Weight	1,25 kg
Dimensions (h x w x d)	130 x 186 x 70 mm
1a) If more PV power is connected, the controller will limit input power to 700W resp. 1400W 1b) PV voltage must exceed Vbat + 5V for the controller to start. Thereafter minimum PV voltage is Vbat + 1V	

BLUESOLAR CHARGE CONTROLLER MPPT 150/70 and MPPT 150/85



**Solar charge controllers
MPPT 150/70 and 150/85**

PV voltage up to 150 V

The BlueSolar MPPT 150/70 and 150/85 charge controllers will charge a lower nominal-voltage battery from a higher nominal voltage PV array.

The controller will automatically adjust to a 12, 24, 36, or 48 V nominal battery voltage.

Ultra fast Maximum Power Point Tracking (MPPT)

Especially in case of a clouded sky, when light intensity is changing continuously, an ultra fast MPPT controller will improve energy harvest by up to 30% compared to PWM charge controllers and by up to 10% compared to slower MPPT controllers.

Advanced Maximum Power Point Detection in case of partial shading conditions

If partial shading occurs, two or more maximum power points may be present on the power-voltage curve. Conventional MPPT's tend to lock to a local MPP, which may not be the optimum MPP.

The innovative BlueSolar algorithm will always maximize energy harvest by locking to the optimum MPP.

Outstanding conversion efficiency

Maximum efficiency exceeds 98%. Full output current up to 40°C (104°F).

Flexible charge algorithm

Several preprogrammed algorithms. One programmable algorithm.

Manual or automatic equalisation.

Battery temperature sensor. Battery voltage sense option.

Programmable auxiliary relay

For alarm or generator start purposes

Extensive electronic protection

Over-temperature protection and power derating when temperature is high.

PV short circuit and PV reverse polarity protection.

Reverse current protection.

BlueSolar charge controller	MPPT 150/70	MPPT 150/85
Nominal battery voltage	12 / 24 / 36 / 48V Auto Select	
Rated charge current	70A @ 40°C (104°F)	85A @ 40°C (104°F)
Maximum solar array input power 1)	12V: 1000W / 24V: 2000W / 36V: 3000W / 48V: 4000W	12V: 1200W / 24V: 2400W / 36V: 3600W / 48V: 4850W
Maximum PV open circuit voltage	150V absolute maximum coldest conditions 145V start-up and operating maximum	
Minimum PV voltage	Battery voltage plus 7 Volt to start	Battery voltage plus 2 Volt operating
Standby power consumption	12V: 0,55W / 24V: 0,75W / 36V: 0,90W / 48V: 1,00W	
Efficiency at full load	12V: 95% / 24V: 96,5% / 36V: 97% / 48V: 97,5%	
Absorption charge	14.4 / 28.8 / 43.2 / 57.6V	
Float charge	13.7 / 27.4 / 41.1 / 54.8V	
Equalization charge	15.0 / 30.0 / 45 / 60V	
Remote battery temperature sensor	Yes	
Default temperature compensation setting	-2,7mV/°C per 2V battery cell	
Remote on/off	No	Yes
Programmable relay	DPST AC rating: 240VAC/4A	DC rating: 4A up to 35VDC, 1A up to 60VDC
Communication port	VE.Can: two paralleled RJ45 connectors, NMEA2000 protocol	
Parallel operation	Yes, through VE.Can. Max 25 units in parallel	
Operating temperature	-40°C to 60°C with output current derating above 40°C	
Cooling	Natural Convection	Low noise fan assisted
Humidity (non condensing)	Max. 95%	
Terminal size	35mm ² / AWG2	
Material & color	Aluminium, blue RAL 5012	
Protection class	IP20	
Weight	4,2 kg	
Dimensions (h x w x d)	350 x 160 x 135 mm	
Mounting	Vertical wall mount	Indoor only
Safety	EN60335-1	
EMC	EN61000-6-1, EN61000-6-3	

1) If more solar power is connected, the controller will limit input power to the stated maximum

PWM CHARGE CONTROLLERS



BlueSolar 12/24-10



BlueSolar DUO 12/24-20



Two remote displays:
- for BlueSolar 12/24-20
- for BlueSolar DUO 12/24-20



BlueSolar 12/24 with timer

BlueSolar 12/24-PWM

Three models: 5A, 10A or 20A at 12V or 24V

- Low cost PWM controller.
- Internal temperature sensor.
- Three stage battery charging (bulk, absorption, float).
- Protected against over current.
- Protected against short circuit.
- Protected against reverse polarity connection of the solar panels and/or battery.
- With low voltage load disconnect output.
- Optional remote display (20A model only)

BlueSolar DUO 12/24-20

20A at 12V or 24V

- PWM controller.
- Charges two separate batteries. For example the starter battery and the service battery of a boat or mobile home.
- Programmable charge current ratio (standard setting: equal current to both batteries).
- Charge voltage settings for three battery types (Gel, AGM and Flooded).
- Internal temperature sensor and optional remote temperature sensor.
- Protected against over current.
- Protected against short circuit.
- Protected against reverse polarity connection of the solar panels and/or battery.

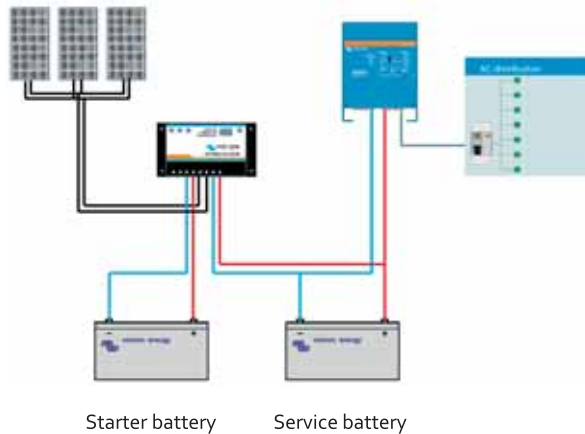

BlueSolar 12/24-10 with timer

10A at 12V or 24V

- PWM solar lighting controller.
- Two timers to enable dusk to dawn operation, or limited time after dusk and limited time before dawn operation.
- Seven segment display to visualize timer settings and analyze fault conditions.
- Battery status indicator with over discharged warning.
- Internal temperature sensor.
- Three stage battery charging (bulk, absorption, float).
- Protected against over current.
- Protected against short circuit.
- Protected against reverse polarity connection of the solar panels and/or battery.
- Low voltage load disconnect override.

PWM CHARGE CONTROLLERS

BlueSolar	BlueSolar 12/24-5 BlueSolar 12/24-10 BlueSolar 12/24-20		BlueSolar DUO 12/24-20		BlueSolar 12/24 with timer	
	12V	24V	12V	24V	12V	24V
Battery Voltage	12/24V Auto Select (1)		12/24V Auto Select (1)		12/24V Auto Select (1)	
Rated charge current	5/10/20A		20A		10A	
Second battery output	No		Yes		No	
Automatic load disconnect	Yes (maximum load 10/10/20A)		n. a.		Yes (maximum load 10A)	
Maximum solar voltage	28/55V (1)		28/55V (1)		28/55V (1)	
Self-consumption	6mA		4mA		5mA	
Default settings						
Absorption charge (2)	14.4V	28.8V	14.4V	28.8V	14.4V	28.8V
Float charge (2)	13.7V	27.4V	13.7V	27.4V	13.7V	27.4V
Equalization charge (2)	n. a.		n. a.		14.8V	29.6V
Low voltage load disconnect	11.1V	22.2V	n. a.		11.1V	22.2V
Low voltage load reconnect	12,6V	25.2V	n. a.		12,6V	25.2V
Enclosure & Environmental						
Battery temperature sensor	Yes Internal sensor		Yes Internal sensor		Yes Internal sensor	
Temperature compensation	-30mV/°C	-60mV/°C	-30mV/°C	-60mV/°C	-30mV/°C	-60mV/°C
Operating temperature	-35°C to +55°C (full load)		-35°C to +55°C (full load)		-35°C to +55°C (full load)	
Cooling	Natural Convection		Natural Convection		Natural Convection	
Humidity (non condensing)	Max. 95%		Max. 95%		Max. 95%	
Protection class	IP20		IP20		IP30	
Terminal size	6mm ² / AWG10		6mm ² / AWG10		6mm ² / AWG10	
Weight	160/160/180gr		180gr		150gr	
Dimension (h x w x d)	70x133x34 mm 70x133x34 mm 76x153x37 mm		76x153x37 mm		65x140x45 mm	
Mounting	Vertical wall mount Indoor only		Vertical wall mount Indoor only		Vertical wall mount Indoor only	
Standards						
Safety	EN60335-1					
EMC	EN61000-6-1, EN61000-6-3					
	1) For 12V use 36 cell Solar panels For 24V use 72 cell Solar panels 2) See manual for alternative charge voltage settings					

12,8 VOLT LITHIUM IRON PHOSPHATE BATTERIES



12,8V 90Ah LiFePO4 battery
LFP-CB 12,8/90
(cell balancing only)

Why lithium-iron phosphate?

Lithium-iron-phosphate (LiFePO₄ or LFP) is the safest of the mainstream li-ion battery types. The nominal voltage of a LFP cell is 3,2V (lead-acid: 2V/cell). A 12,8V LFP battery therefore consists of 4 cells connected in series; and a 25,6V battery consists of 8 cells connected in series.

Rugged

A lead-acid battery will fail prematurely due to sulfation if:

- If it operates in deficit mode during long periods of time (i. e. if the battery is rarely, or never at all, fully charged).
- If it is left partially charged or worse, fully discharged (yacht or mobile home during winter time).

A LFP battery does not need to be fully charged. Service life even slightly improves in case of partial charge instead of a full charge. This is a major advantage of LFP compared to lead-acid.

Other advantages are the wide operating temperature range, excellent cycling performance, low internal resistance and high efficiency (see below).

LFP is therefore the chemistry of choice for very demanding applications.

Efficient

In several applications (especially off-grid solar and/or wind), energy efficiency can be of crucial importance. The round trip energy efficiency (discharge from 100% to 0% and back to 100% charged) of the average lead-acid battery is 80%.

The round trip energy efficiency of a LFP battery is 92%.

The charge process of lead-acid batteries becomes particularly inefficient when the 80% state of charge has been reached, resulting in efficiencies of 50% or even less in solar systems where several days of reserve energy is required (battery operating in 70% to 100% charged state).

In contrast, a LFP battery will still achieve 90% efficiency under shallow discharge conditions.

Size and weight

Saves up to 70% in space

Saves up to 70% in weight

Expensive?

LFP batteries are expensive when compared to lead-acid. But in demanding applications, the high initial cost will be more than compensated by longer service life, superior reliability and excellent efficiency.

Endless flexibility

LFP batteries are easier to charge than lead-acid batteries. The charge voltage may vary from 14V to 16V (as long as no cell is subjected to more than 4,2V), and they do not need to be fully charged. Therefore several batteries can be connected in parallel and no damage will occur if some batteries are less charged than others.

With or without Battery Management System (BMS)?

Important facts:

1. A LFP cell will fail if the voltage over the cell falls to less than 2,5V.
2. A LFP cell will fail if the voltage over the cell increases to more than 4,2V.

Lead-acid batteries will eventually also be damaged when discharged too deeply or overcharged, but not immediately. A lead-acid battery will recover from total discharge even after it has been left in discharged state during days or weeks (depending on battery type and brand).

3. The cells of a LFP battery do not auto-balance at the end of the charge cycle.

The cells in a battery are not 100% identical. Therefore, when cycled, some cells will be fully charged or discharged earlier than others. The differences will increase if the cells are not balanced/equalized from time to time.

In a lead-acid battery a small current will continue to flow even after one or more cells are fully charged (the main effect of this current is decomposition of water into hydrogen and oxygen). This current helps to fully charge other cells that are lagging behind, thus equalizing the charge state of all cells.

The current through a LFP cell however, when fully charged, is nearly zero, and lagging cells will therefore not be fully charged. The differences between cells may become some so extreme over time that, even though the overall battery voltage is within limits, some cells will be destroyed due to over- or under-voltage. Cell balancing is therefore highly recommended.

In addition to cell balancing, a BMS will:

- Prevent cell under voltage by timely disconnecting the load.
- Prevent cell overvoltage by reducing charge current or stopping the charge process.
- Shut down the system in case of over temperature.

A BMS is therefore indispensable to prevent damage to large Li-ion battery banks.



12,8V 90Ah LiFePO4 battery
LFP-BMS 12,8/90
(cell balancing and BMS interface)

12,8 VOLT LITHIUM IRON PHOSPHATE BATTERIES

With cell balancing, but without BMS: 12,8V LFP batteries for light duty applications

In applications where excessive discharge (to less than 11V), overcharge (to more than 15V) or excessive charge current will never occur, 12,8V batteries with cell balancing only may be used.

Please note that these batteries are not suitable for series or parallel connection.

Notes:

1. A Battery Protect module (see www.victronenergy.com) may be used to prevent excessive discharge.
2. The current draw of inverters and inverter/chargers is often still significant (0,1A or more) after low voltage shutdown. The remaining stand-by current will therefore damage the battery if the inverters or inverter/chargers are left connected to the battery after low voltage shutdown during a long period of time.

With cell balancing and interface to connect to a Victron BMS: 12,8V LFP batteries for heavy duty applications and parallel/series connection

These batteries have integrated Cell Balancing, Temperature and Voltage control (BTV). Up to ten batteries can be paralleled and up to four batteries can be series connected (BTV's are simply daisy-chained) so that a 48V battery bank of up to 2000Ah can be assembled. The daisy-chained BTV's must be connected to a battery management system (BMS).

Battery Management System (BMS)

The BMS connects to the BTV's and its essential functions are:

1. Disconnect or shut down the load whenever the voltage of a battery cell falls to less than 2,5V.
2. Stop the charging process whenever the voltage of a battery cell increases to more than 4,2V.
3. Shut down the system whenever the temperature of a cell exceeds 50°C.

More features may be included: see the individual BMS datasheets.

Battery specification								
	Cell balancing only				Cell balancing and BMS interface			
VOLTAGE AND CAPACITY	LFP-CB 12,8/60	LFP-CB 12,8/90	LFP-CB 12,8/160	LFP-CB 12,8/200	LFP-BMS 12,8/60	LFP-BMS 12,8/90	LFP-BMS 12,8/160	LFP-BMS 12,8/200
Nominal voltage	12,8V	12,8V	12,8V	12,8V	12,8V	12,8V	12,8V	12,8V
Nominal capacity @ 25°C*	60Ah	90Ah	160Ah	200Ah	60Ah	90Ah	160Ah	200Ah
Nominal capacity @ 0°C*	48Ah	72Ah	130Ah	160Ah	48Ah	72Ah	130Ah	160Ah
Nominal capacity @ -20°C*	30Ah	45Ah	80Ah	100Ah	30Ah	45Ah	80Ah	100Ah
Nominal energy @ 25°C*	768Wh	1152Wh	2048Wh	2560Wh	768Wh	1152Wh	2048Wh	2560Wh
*Discharge current ≤1C								
CYCLE LIFE								
80% DoD	2000 cycles							
70% DoD	3000 cycles							
50% DoD	5000 cycles							
DISCHARGE								
Maximum continuous discharge current	180A	270A	400A	500A	180A	270A	400A	500A
Recommended continuous discharge current	≤60A	≤90A	≤160A	≤200A	≤60A	≤90A	≤160A	≤200A
Maximum 10 s pulse current	600A	900A	1200A	1500A	600A	900A	1200A	1500A
End of discharge voltage	11V	11V	11V	11V	11V	11V	11V	11V
OPERATING CONDITIONS								
Operating temperature	-20°C to +50°C (do not charge when battery temperature < 0°C)							
Storage temperature	-45°C to +70°C							
Humidity (non condensing)	Max. 95%							
Protection class	IP 54							
CHARGE								
Charge voltage	Between 14V and 15V (<14,5V recommended)							
Float voltage	13,6V							
Maximum charge current	60A	90A	160A	200A	180A	270A	400A	500A
Recommended charge current	≤20A	≤25A	≤40A	≤50A	≤30A	≤45A	≤80A	≤100A
OTHER								
Max storage time @ 25 °C*	1 year							
Dimensions (hxwx d) mm	235x293x139	249x293x168	320x338x233	295x425x274	235x293x139	249x293x168	320x338x233	295x425x274
Weight	12kg	16kg	33kg	42kg	12kg	16kg	33kg	42kg
*When fully charged								

BMS 12/200 FOR 12,8 VOLT LITHIUM IRON PHOSPHATE BATTERIES

Especially designed for vehicles and boats



12,8V 90Ah LiFePO4 battery



12,8V 60Ah LiFePO4 battery

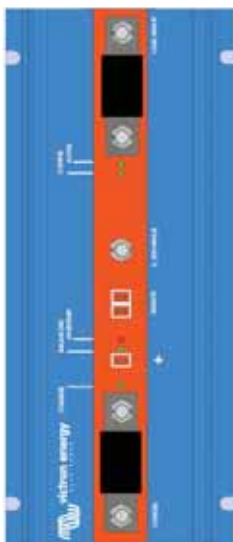

BMS 12/200 with:

- 12V 200A load output, short-circuit proof
- Li-ion battery over-discharge protection
- starter battery discharge protection
- adjustable alternator current limit
- remote on-off switch

Why lithium-iron phosphate?

Lithium-iron-phosphate (LiFePO₄ or LFP) is the safest of the mainstream li-ion battery types. The nominal voltage of a LFP cell is 3,2V (lead-acid: 2V/cell). A 12,8V LFP battery therefore consists of 4 cells connected in series; and a 25,6V battery consists of 8 cells connected in series.

Why a Battery Management System (BMS) is needed:

1. A LFP cell will be damaged if the voltage over the cell falls to less than 2,5V.
2. A LFP cell will be damaged if the voltage over the cell increases to more than 4,2V.

Lead-acid batteries will eventually also be damaged when discharged too deeply or overcharged, but not immediately. A lead-acid battery will recover from total discharge even after it has been left in discharged state during days or weeks (depending on battery type and brand).

3. The cells of a LFP battery do not auto-balance at the end of the charge cycle.

The cells in a battery are not 100% identical. Therefore, when cycled, some cells will be fully charged or discharged earlier than others. The differences will increase if the cells are not balanced/equalized from time to time.

In a lead-acid battery a small current will continue to flow even after one or more cells are fully charged (the main effect of this current is decomposition of water into hydrogen and oxygen). This current helps to fully charge other cells that are lagging behind, thus equalizing the charge state of all cells.

The current through a LFP cell however, when fully charged, is nearly zero, and lagging cells will therefore not be fully charged. The differences between cells may become some so extreme over time that, even though the overall battery voltage is within limits, some cells will be destroyed due to over- or under-voltage.

A LFP battery therefore must be protected by a BMS that actively balances the individual cells and prevents under- and over-voltage.

Rugged

A lead-acid battery will fail prematurely due to sulfation if:

- If it operates in deficit mode during long periods of time (the battery is rarely, or never at all, fully charged).
- If it is left partially charged or worse, fully discharged (yacht or mobile home during winter time).

A LFP battery does not need to be fully charged. Service life even slightly improves in case of partial charge instead of a full charge. This is a major advantage of LFP compared to lead-acid.

Other advantages are the wide operating temperature range, excellent cycling performance, low internal resistance and high efficiency (see below).

LFP is therefore the chemistry of choice for very demanding applications.

Efficient

In several applications (especially off-grid solar and/or wind), energy efficiency can be of crucial importance. The round trip energy efficiency (discharge from 100% to 0% and back to 100% charged) of the average lead-acid battery is 80%.

The round trip energy efficiency of a LFP battery is 92%.

The charge process of lead-acid batteries becomes particularly inefficient when the 80% state of charge has been reached, resulting in efficiencies of 50% or even less in solar systems where several days of reserve energy is required (battery operating in 70% to 100% charged state).

In contrast, a LFP battery will still achieve 90% efficiency under shallow discharge conditions.

Size and weight

Saves up to 70% in space
Saves up to 70% in weight

Expensive?

LFP batteries are expensive when compared to lead-acid. But in demanding applications, the high initial cost will be more than compensated by longer service life, superior reliability and excellent efficiency.

Endless flexibility

LFP batteries are easier to charge than lead-acid batteries. The charge voltage may vary from 14V to 16V (as long as no cell is subjected to more than 4,2V), and they do not need to be fully charged.

Several batteries can be connected in parallel and no damage will occur if some batteries are less charged than others.

Our 12V BMS will support up to 10 batteries in parallel (BTV's are simply daisy-chained).

BMS 12/200 FOR 12,8 VOLT LITHIUM IRON PHOSPHATE BATTERIES

A 12V BMS that protects the alternator (and wiring), and supplies up to 200A in any DC load (including inverters and inverter/chargers)

Alternator/battery charger input (Power Port AB)

1. The first function of Power Port AB is to prevent the load connected to the LFP battery from discharging the starter battery. This function is similar to that of a Cyrix battery combiner or Argo FET battery isolator. Current can flow to the LFP battery only if the input voltage (= voltage on the starter battery) exceeds 13V.
2. Current cannot flow back from the LFP battery to the starter battery, thus preventing eventual damage to the LFP battery due to excessive discharge.
3. Excessive input voltage and transients are regulated down to a safe level.
4. Charge current is reduced to a safe level in case of cell unbalance or over temperature.
5. The input current is electronically limited to approximately 80% of the AB fuse rating. A 50A fuse, for example, will therefore limit the input current to 40A. Choosing the right fuse will therefore:
 - a. Protect the LFP battery against excessive charge current (important in case of a low capacity LFP battery).
 - b. Protect the alternator against overload in case of a high capacity LFP battery bank (most 12V alternators will overheat and fail if running at maximum output during more than 15 minutes).
 - c. Limit charge current in order not to exceed the current handling capability of the wiring.

The maximum fuse rating is 100A (limiting charge current to approximately 80A).

Load/battery charger output/input (Power Port LB)

1. Maximum current in both directions: 200A continuous.
2. Peak discharge current electronically limited to 400A.
3. Battery discharge cut-off whenever the weakest cell falls below 3V.
4. Charge current is reduced to a safe level in case of cell unbalance or over temperature.

BMS 12/200 specification	
Maximum number of 12,8V batteries	10
Maximum charge current, Power Port AB	80A @ 40°C
Maximum charge current, Power Port LB	200A @ 40°C
Maximum continuous discharge current, LB	200A @ 40°C
Peak discharge current, LB (short circuit proof)	400A
Approximate cut-off voltage	11V
GENERAL	
No load current when operating	10mA
Current consumption when switched off (discharging is stopped and charging remains enabled, both through AB and LB, when switched off)	5mA
Current consumption after battery discharge cut-off due to low cell voltage	3mA
Operating temperature range	-40 to +60°C
Humidity, maximum	100%
Humidity, average	95%
Protection, electronics	IP65
DC connection AB, LB and battery minus	M8
DC connection battery plus	Faston female 6.3 mm
LED's	
Battery being charged through Power Port AB	green
Battery being charged through Power Port LB	green
Power port LB active	green
Over temperature	red
ENCLOSURE	
Weight (kg)	1,8
Dimensions (hwxwd in mm)	65 x 120 x 260
STANDARDS	
Emission	EN 50081-1
Immunity	EN 50082-1
Automotive Directive	2004/104/EC

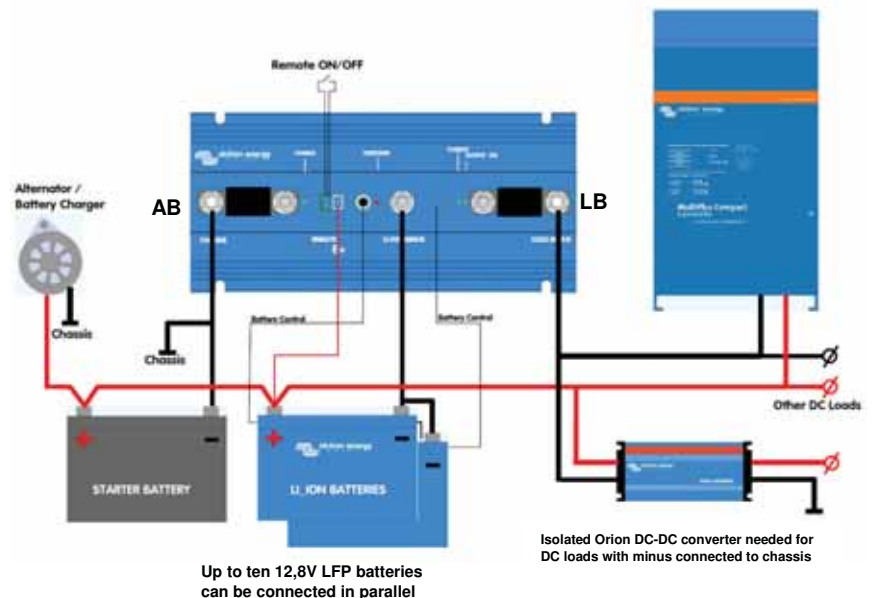

24V 180AH LITHIUM-ION BATTERY AND LYNX-ION



24V 180Ah Lithium-ion battery

The advantages of a Lithium-ion battery over conventional lead-acid batteries

- High energy density: more energy with less weight;
- High charge currents (shortens the charge period);
- High discharge currents (enabling for example electrical cooking on a small battery bank);
- Long battery life (up to six times the battery life of a conventional battery);
- High efficiency between charging and discharging (very little energy loss due to heat development);
- Higher continuous power available.

Why Lithium-iron phosphate?

Lithium-iron-phosphate (LiFePO₄ or LFP) is the safest of the mainstream Li-ion battery types. The nominal voltage of a LFP cell is 3,2V (lead-acid: 2V/cell). A 25,6V LFP battery consists of 8 cells connected in series.

The advantages of the Victron Lynx Lithium-ion battery system

The modular system used adds below advantages:

- The Victron Lithium-ion battery system is easy to install due to its modularity. No complicated wiring diagrams are required.
- Detailed information is available on the waterproof Ion Control display.
- The 350A relay in the Lynx Ion provides maximum safety: in case the chargers or loads do not listen to the commands from the Lynx Ion, the main safety relay will open to prevent permanent damage to the batteries.
- For typical marine installations there is an extra smaller output, so you can still power the bilge pump and disconnect all other house loads by opening the 350A relay.



Lynx Ion

Complete system

A complete system consists of:

- One or more **24V 180Ah Lithium-Ion batteries**.
- (optional) The **Lynx Power In**, a modular dc bus bar.
- The **Lynx Ion** is the battery management system (BMS) that controls the batteries. A 350 Ampère safety contactor is inside the Lynx Ion.
- The **Lynx Shunt VE.Can**, a battery monitor including the main fuse. Note that the fuse needs to be purchased separately.
- (optional) The **Lynx Distributor**, a DC distribution system with fuses.
- (optional) The **Ion Control**, a digital control panel.



Ion control: Main screen

24V 180Ah Lithium-Ion Batteries

The base of the Victron Lithium-ion battery system is formed by individual 24V/180Ah Lithium-ion batteries. They have a built-in Cell Management System (BMS) which protects the battery on a cell level. It monitors individual cell voltage and system temperature, and actively balances the individual cells. All measured parameters are sent to the Lynx Ion which monitors the system as a whole.

Lynx Ion

The Lynx Ion is the BMS. It contains the 350A safety contactor, and controls the cell-balancing, charging and discharging of the system. The Lynx Ion will protect the battery pack from both overcharging and depletion. When an overcharge is imminent, it will signal the charging devices to decrease or stop charging. This is done with the VE.Can bus (NMEA2000) compatible, and also via the two available open/close contacts. Same when the battery is nearing empty, and there is no charging capability available. It will signal big loads to switch off.

For both over charging and depletion there is a last safety resort, the built-in 350A contactor. In case signaling etcetera does not stop the imminent overcharge or depletion, it will open the contactor.

NMEA2000 Canbus

Communication with the outside world is done via the VE.Can protocol.

Ion Control

See the separate [Ion Control](#) datasheet for more information on the display.



Ion control: History screen



Ion control: Lynx Ion Status

24V 180AH LITHIUM-ION BATTERY AND LYNX-ION

Lithium-ion 24V 180Ah 4.75kWh battery	
Technology	Lithium iron phosphate (LiFePo4)
Nominal voltage	26,4 V
Nominal capacity	180 Ah
Nominal power	4,75 kWh
Weight	55 kg
Power/Weight ratio	86 Wh/kg
Dimensions (LxWxH)	625 x 195 x 355 mm
Charge cut-off voltage at 0.05C	28,8 V
Discharge cut-off voltage	20 V
Recommended charge/discharge current	54 A (0,3C)
Maximum charge current (1C)	180 A
Maximum discharge current (1.5C)	270 A
Pulse discharge current (10s)	1000 A
Cycle Life @80% DOD (0.3C)	2000
Series configuration	Yes, up to 2 (more in series on request)
Parallel configuration	Yes, easy up to 4 (more parallel on request)
Operating temp. charge	0~45 °C
Operating temp. discharge	-20~55 °C
Storage temp.	-20~45 °C

Lynx Ion	
Maximum number batteries in series	2
Maximum number batteries in parallel	8
Enclosure	
Weight	1,4 kg
Dimensions (LxWxH)	190 x 180 x 80 mm
IO	
Safety contactor	350 A
Bilge pump contactor maximum current	10 A
External relay contactor maximum current	10 A
Charged-signal contact	1A @ 60VDC
Discharged-signal contact	1A @ 60VDC
Standards	
Emission	EN 50081-1
Immunity	EN 50082-1

Block diagram Lithium-ion battery system

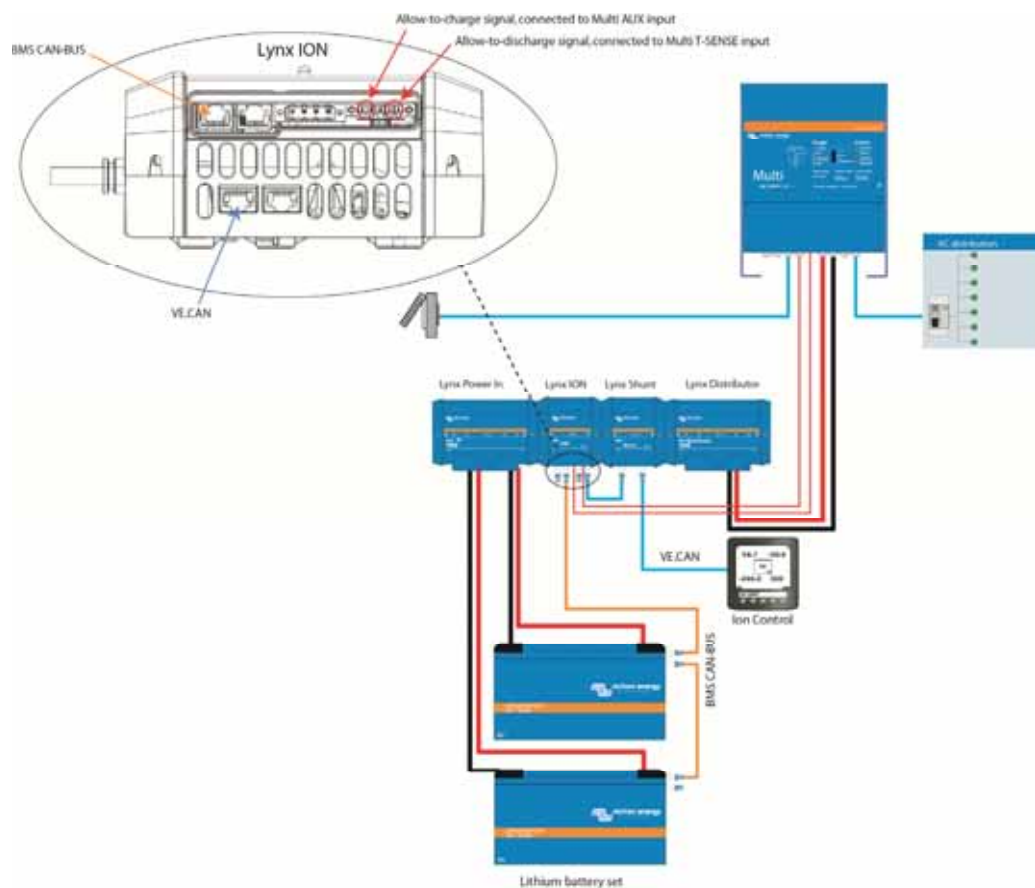

ION CONTROL



Main screen



History screen



Diagnostics screen 1



Diagnostics screen 2



Lynx Ion Status



Ion Control

The Ion Control shows all vital data from the Lithium Battery system:

- Battery voltage (V)
- Battery charge/discharge current (A)
- Ampere-hours consumed (Ah)
- State of charge (%)
- Time to go at the current rate of discharge until the battery has reached 90% discharge
- Visual alarm: almost charged, almost discharged

It will also show the following historic values:

- The depth of the deepest discharge
- The cumulative number of Amp hours drawn from the battery
- The minimum battery voltage
- The maximum battery voltage
- The minimum cell voltage
- The maximum cell voltage

The diagnostic data displayed is:

- Software versions of the system components
- Total number of automatic system shutdowns, caused by an error
- Last four errors that occurred in the system

Using multiple Ion Controls

Multiple Ion Controls can be installed to monitor a single Lithium Battery System. All Ion Controls will display the same data. It is recommended, when more than one Ion Control is installed, to use an external network power source due to the limited capacity of the Lynx Shunt's power supply.

ELECTRICAL	
Power supply voltage range	10 – 32 V DC No need for an external power supply. Power is supplied on the VE.Can by the Lynx Shunt
Power consumption	130mA at 12VDC
Audible Alarm	4kHz Internal sounder
Connections	Integral Deutsch 12 way connector (DT04-12PA)
Cabling supplied	15cm Deutsch 12 way to Victron RJ45 Canbus connection
Communications	NMEA2000 (expects battery instance 0)
ENVIRONMENTAL	
Operating temperature	-25 to +75°C
Degree of Protection	IP67
Salt Spray	IEC 60068-2-52: 1996
EMC	IEC 61000 and EN55022
ENCLOSURE	
Material & Colour	Anthracite Grey ABS housing and acrylic lens
Dimensions	110mm x 110mm x 38.5mm deep (without connector)
Depth front mounted	21.5mm forward protrusion, 17mm rear protrusion (without connector)
Panel cut out	64mm diameter hole with 4 mount holes, 4.3mm dia.
Weight	265 grams



Ion Control VE.Can cable assembly (included)



ION CONTROL

Modes of operation

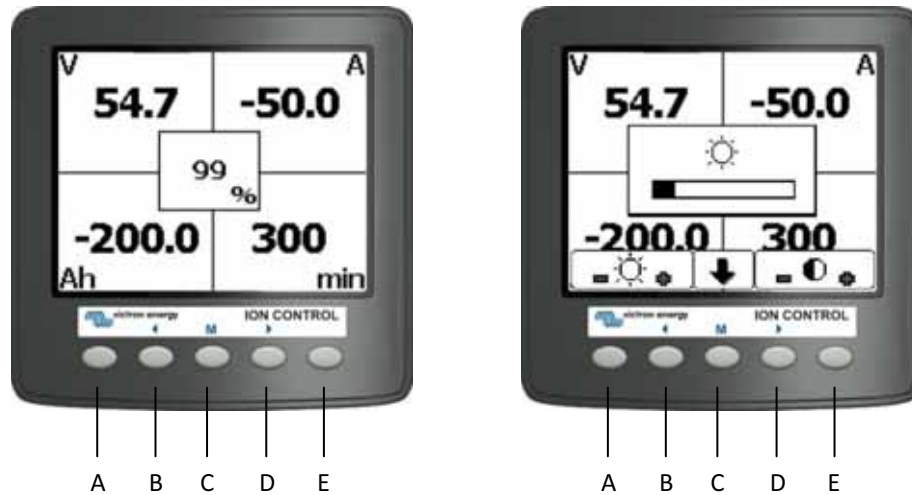

Browsing

To browse through the screens the keys [D] and [B] are used. Press [D] to continue to the next screen and press [B] to go to the previous screen.

Lighting and contrast

To enter this menu press [C], a popup window will appear. To alter the intensity of the backlight use [A] and [B]. The LCD contrast can be changed using [D] and [E].

Pressing [C] will store the settings and exit the menu.

Reset

To reset the Ion Control, press [A] and [E] simultaneously. This feature is introduced in firmware version v1.07.

System Diagram

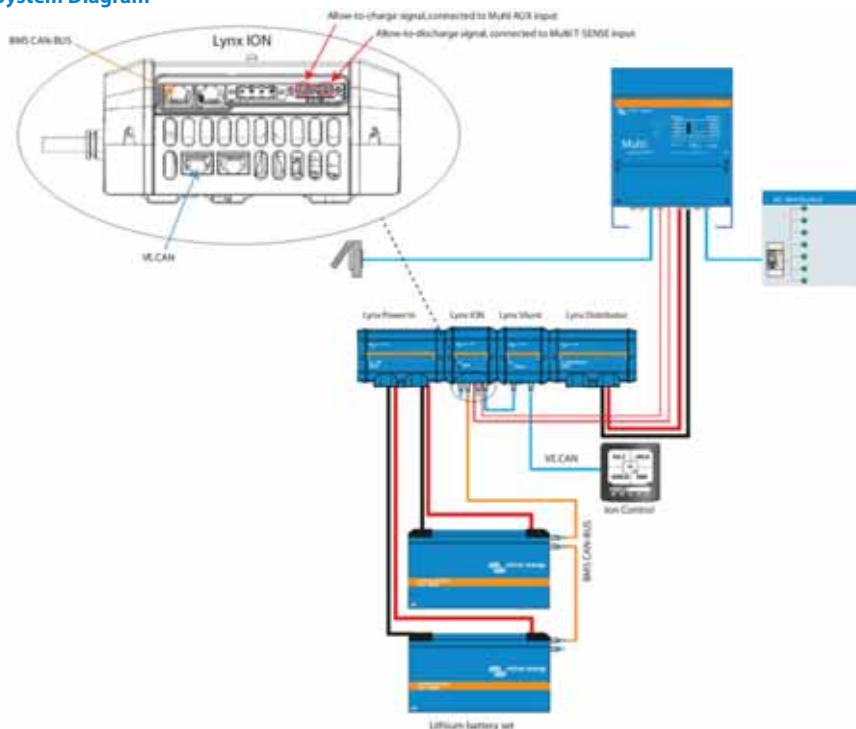

ION CONTROL

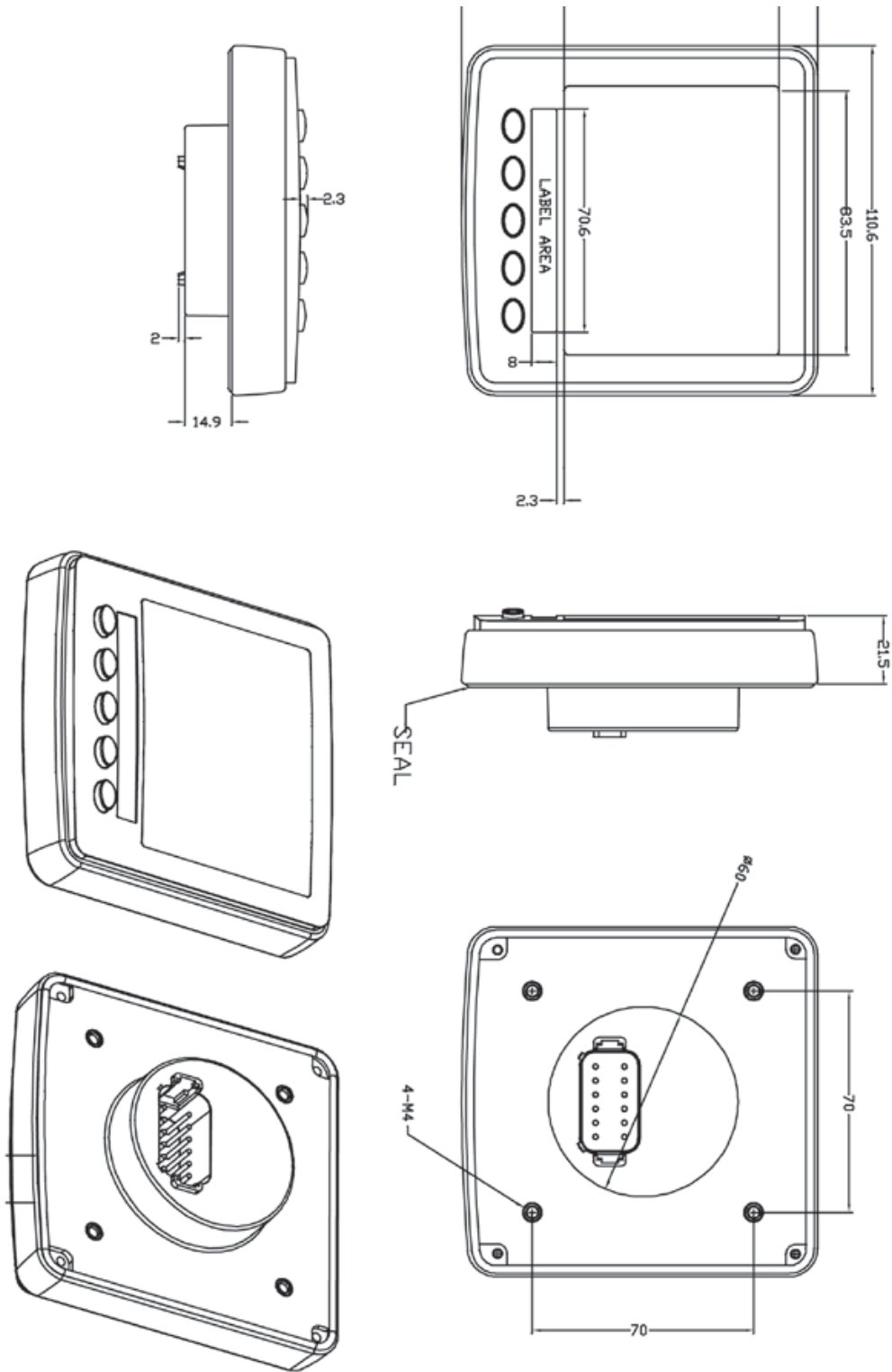



GEL AND AGM BATTERIES



**AGM battery
12V 90Ah**



GEL OPzV 2V cell

1. VRLA technology

VRLA stands for Valve Regulated Lead Acid, which means the batteries are sealed. Gas will escape through the safety valves only in case of overcharging or cell failure.

VRLA batteries are maintenance free for life.

2. Sealed (VRLA) AGM batteries

AGM stands for Absorbent Glass Mat. In these batteries the electrolyte is absorbed into a glass-fibre mat between the plates by capillary action. As explained in our book 'Energy Unlimited', AGM batteries are more suitable for short-time delivery of very high currents (engine starting) than gel batteries.

3. Sealed (VRLA) Gel batteries

Here the electrolyte is immobilized as gel. Gel batteries in general have a longer service life and better cycle capacity than AGM batteries.

4. Low Self-discharge

Because of the use of lead calcium grids and high purity materials, Victron VRLA batteries can be stored during long periods of time without recharge. The rate of self-discharge is less than 2% per month at 20°C. The self discharge doubles for every increase in temperature with 10°C.

Victron VRLA batteries can therefore be stored during up to a year without recharging, if kept under cool conditions.

5. Exceptional Deep Discharge Recovery

Victron VRLA batteries have exceptional discharge recovery, even after deep or prolonged discharge.

It should however be stressed that repetitive deep discharge and prolonged discharge have a very negative influence on the service life of all lead acid batteries, Victron batteries are no exception.

6. Battery discharging characteristics

The rated capacity of Victron AGM and Gel Deep Cycle batteries refers to 20 hour discharge, in other words: a discharge current of 0,05 C.

The rated capacity of Victron Tubular Plate Long Life batteries refers to 10 hours discharge.

The effective capacity decreases with increasing discharge current (see table 1). Please note that the capacity reduction will be even faster in case of a constant power load, such as an inverter.

Discharge time (constant current)	End Voltage V	AGM 'Deep Cycle' %	Gel 'Deep Cycle' %	Gel 'Long Life' %
20 hours	10,8	100	100	112
10 hours	10,8	92	87	100
5 hours	10,8	85	80	94
3 hours	10,8	78	73	79
1 hour	9,6	65	61	63
30 min.	9,6	55	51	45
15 min.	9,6	42	38	29
10 min.	9,6	38	34	21
5 min.	9,6	27	24	
5 seconds		8 C	7 C	

Table 1: Effective capacity as a function of discharge time (the lowest row gives the maximum allowable 5 seconds discharge current)

Our AGM deep cycle batteries have excellent high current performance and are therefore recommended for high current applications such as engine starting. Due to their construction, Gel batteries have a lower effective capacity at high discharge currents. On the other hand, Gel batteries have a longer service life, both under float and cycling conditions.

7. Effect of temperature on service life

High temperature has a very negative effect on service life. The service life of Victron batteries as a function of temperature is shown in table 2.

Average Temperature	AGM Deep Cycle years	Gel Deep Cycle years	Gel Long Life years
20°C / 68°F	7 - 10	12	20
30°C / 86°F	4	6	10
40°C / 104°F	2	3	5

Table 2: Design service life of Victron batteries under float service

GEL AND AGM BATTERIES

8. Effect of temperature on capacity

As is shown by the graph below, capacity reduces sharply at low temperatures.

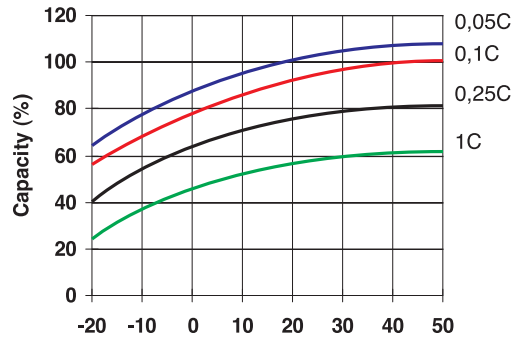

Fig. 1: Effect of temperature on capacity

9. Cycle life of Victron batteries

Batteries age due to discharging and recharging. The number of cycles depends on the depth of discharge, as is shown in figure 2.

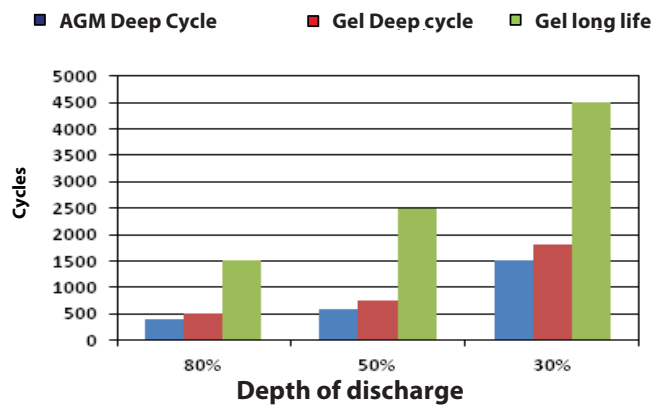

Fig. 2: Cycle life

10. Battery charging in case of cycle use: the 3-step charge curve

The most common charge curve used to charge VRLA batteries in case of cyclic use is the 3-step charge curve, whereby a constant current phase (the bulk phase) is followed by two constant voltage phases (absorption and float), see fig. 3.

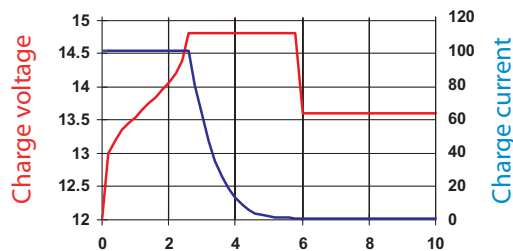

Fig. 3: Three step charge curve

During the absorption phase the charge voltage is kept at a relatively high level in order to fully recharge the battery within reasonable time. The third and last phase is the float phase: the voltage is lowered to standby level, sufficient to compensate for self discharge.

GEL AND AGM BATTERIES

Disadvantages of the traditional 3-step charge curve:

- During the bulk phase the current is kept at a constant and often high level, even after the gassing voltage (14,34 V for a 12 V battery) has been exceeded. This can lead to excessive gas pressure in the battery. Some gas will escape through the safety valves, reducing service life.
- Thereafter the absorption voltage is applied during a fixed period of time, irrespective of how deep the battery has been discharged previously. A full absorption period after a shallow discharge will overcharge the battery, again reducing service life. (a. o. due to accelerated corrosion of the positive plates)
- Research has shown that battery life can be increased by decreasing float voltage to an even lower level when the battery is not in use.

11. Battery charging: longer battery life with Victron 4-step adaptive charging

Victron developed the adaptive charge curve. The 4-step adaptive charge curve is the result of years of research and testing.

The Victron four-step adaptive charge curve solves the 3 main problems of the 3 step curve:

- **Battery Safe mode**
In order to prevent excessive gassing, Victron has invented the 'Battery Safe Mode'. The battery Safe Mode will limit the rate of voltage increase once the gassing voltage has been reached. Research has shown that this will reduce internal gassing to a safe level.
- **Variable absorption time**
Based on the duration of the bulk stage, the charger calculates how long the absorption time should be in order to fully charge the battery. If the bulk time is short, this means the battery was already charged and the resulting absorption time will also be short, whereas a longer bulk time will also result in a longer absorption time.
- **Storage mode**
After completion of the absorption period the battery should be fully charged, and the voltage is lowered to the float or standby level. If no discharge occurs during the next 24 hours, the voltage is reduced even further and the battery goes into storage mode. The lower storage voltage reduces corrosion of the positive plates. Once every week the charge voltage is increased to the absorption level for a short period to compensate for self discharge (Battery Refresh mode).

12. Battery charging in case of standby use: constant voltage float charging

When a battery is not frequently deeply discharged, a 2-step charge curve can be used. During the first phase the battery is charged with a limited current (the bulk phase). Once a preset voltage has been reached the battery is kept at that voltage (the float phase).

This charge method is used for starter batteries in vehicles, and in uninterruptible power supplies (UPS).

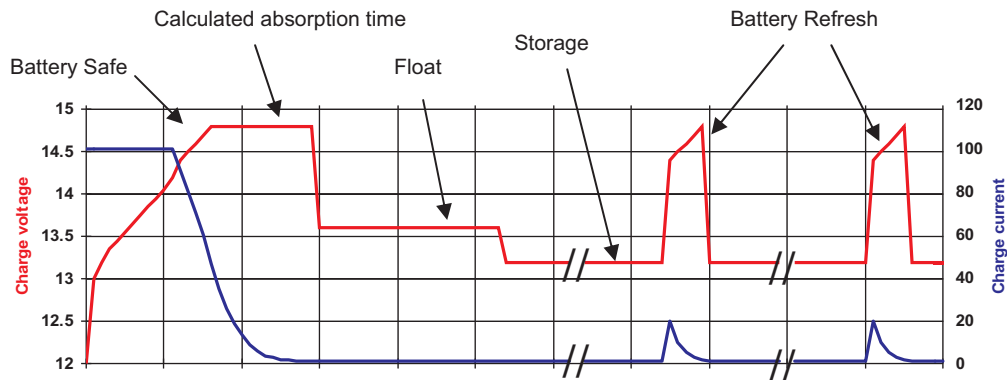

Fig. 4: Four-step adaptive charge curve

13. Optimum charge voltage of Victron VRLA batteries

The recommended charge voltage settings for a 12 V battery are shown in table 3.

14. Effect of temperature on charging voltage

The charge voltage should be reduced with increased temperature. Temperature compensation is required when the temperature of the battery is expected to be less than 10°C / 50°F or more than 30°C / 85°F during long periods of time. The recommended temperature compensation for Victron VRLA batteries is -4 mV / Cell (-24 mV / °C for a 12 V battery). The centre point for temperature compensation is 20°C / 70°F.

15. Charge current

The charge current should preferably not exceed 0,2 C (20 A for a 100 Ah battery). The temperature of a battery will increase by more than 10°C if the charge current exceeds 0,2 C. Therefore temperature compensation is required if the charge current exceeds 0,2 C.

GEL AND AGM BATTERIES

	Float Service (V)	Cycle service Normal (V)	Cycle service Fastest recharge (V)
Victron AGM "Deep Cycle"			
Absorption		14,2 - 14,6	14,6 - 14,9
Float	13,5 - 13,8	13,5 - 13,8	13,5 - 13,8
Storage	13,2 - 13,5	13,2 - 13,5	13,2 - 13,5
Victron Gel "Deep Cycle"			
Absorption		14,1 - 14,4	
Float	13,5 - 13,8	13,5 - 13,8	
Storage	13,2 - 13,5	13,2 - 13,5	
Victron Gel "Long Life"			
Absorption		14,0 - 14,2	
Float	13,5 - 13,8	13,5 - 13,8	
Storage	13,2 - 13,5	13,2 - 13,5	

Table 3: Recommended charge voltage

12 Volt Deep Cycle AGM							General Specification
Article number	Ah	V	l x w x h mm	Weight kg	CCA @0 °F	RES CAP @80 °F	Technology: flat plate AGM Terminals: copper
BAT406225080	240	6	320x176x247	31	1500	480	Rated capacity: 20 hr discharge at 25 °C Float design life: 7-10 years at 20 °C Cycle design life: 400 cycles at 80% discharge 600 cycles at 50% discharge 1500 cycles at 30% discharge
BAT212070080	8	12	151x65x101	2,5			
BAT212120080	14	12	151x98x101	4,1			
BAT212200080	22	12	181x77x167	5,8			
BAT412350080	38	12	197x165x170	12,5			
BAT412550080	60	12	229x138x227	20	450	90	
BAT412600080	66	12	258x166x235	24	520	100	
BAT412800080	90	12	350x167x183	27	600	145	
BAT412101080	110	12	330x171x220	32	800	190	
BAT412121080	130	12	410x176x227	38	1000	230	
BAT412151080	165	12	485x172x240	47	1200	320	
BAT412201080	220	12	522x238x240	65	1400	440	

12 Volt Deep Cycle GEL							General Specification
Article number	Ah	V	l x w x h mm	Weight kg	CCA @0 °F	RES CAP @80 °F	Technology: flat plate GEL Terminals: copper
BAT412550100	60	12	229x138x227	20	300	80	Rated capacity: 20 hr discharge at 25 °C Float design life: 12 years at 20 °C Cycle design life: 500 cycles at 80% discharge 750 cycles at 50% discharge 1800 cycles at 30% discharge
BAT412600100	66	12	258x166x235	24	360	90	
BAT412800100	90	12	350x167x183	26	420	130	
BAT412101100	110	12	330x171x220	33	550	180	
BAT412121100	130	12	410x176x227	38	700	230	
BAT412151100	165	12	485x172x240	48	850	320	
BAT412201100	220	12	522x238x240	66	1100	440	

2 Volt Long Life GEL					General Specification
Article number	Ah	V	l x b x h mm	Weight kg	Technology: tubular plate GEL Terminals: copper
BAT702601260	600	2	145x206x688	49	Rated capacity: 10 hr discharge at 25 °C Float design life: 20 years at 20 °C Cycle design life: 1500 cycles at 80% discharge 2500 cycles at 50% discharge 4500 cycles at 30% discharge
BAT702801260	800	2	210x191x688	65	
BAT702102260	1000	2	210x233x690	80	
BAT702122260	1200	2	210x275x690	93	
BAT702152260	1500	2	210x275x840	115	
BAT702202260	2000	2	215x400x815	155	
BAT702252260	2500	2	215x490x815	200	
BAT702302260	3000	2	215x580x815	235	

Other capacities and terminal types: at request

BLUESOLAR MONOCRYSTALLINE PANELS

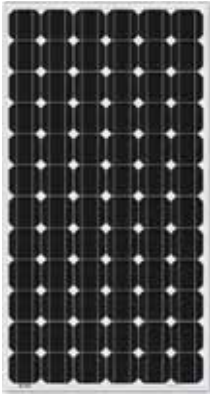

BlueSolar Monocrystalline 280W

- Low voltage-temperature coefficient enhances high-temperature operation.
- Exceptional low-light performance and high sensitivity to light across the entire solar spectrum.
- 25-year limited warranty on power output and performance.
- 2-year limited warranty on materials and workmanship.
- Sealed, waterproof, multi-functional junction box gives high level of safety.
- High performance bypass diodes minimize the power drop caused by shade.
- Advanced EVA (Ethylene Vinyl Acetate) encapsulation system with triple-layer back sheet meets the most stringent safety requirements for high-voltage operation.
- A sturdy, anodized aluminum frame allows modules to be easily roof-mounted with a variety of standard mounting systems.
- Highest quality, high-transmission tempered glass provides enhanced stiffness and impact resistance.
- Pre wired quick-connect system with MC4 (PV-ST01) connectors.
(Except for the 30W panel)



MC4 connectors

Type	Module Size	Glass size	Weight	Electrical data under STC ⁽¹⁾				
				Nominal Power	Max-Power Voltage	Max-Power Current	Open-Circuit Voltage	Short-circuit Current
				P _{MPP}	V _{MPP}	I _{MPP}	V _{oc}	I _{sc}
Module	mm	mm	Kg	W	V	A	V	A
SPM30-12	450 x 540 x 25	445 x 535	2.5	30	18	1.67	22.5	2
SPM51-12	645 x 540 x 35	640 x 535	5.2	50	18	2.78	22.2	3.16
SPM81-12	1005 x 540 x 35	1000 x 535	7	80	18	4.45	22.3	4.96
SPM101-12	1210 x 540 x 35	1205 x 535	8	100	18	5.56	22.4	6.53
SPM131-12	1110 x 808 x 35	1105 x 802	11.5	130	18	7.23	22.4	78.03
SPM190-24	1580 x 808 x 35	1574 x 802	14.5	190	36	5.44	43.2	5.98
SPM300-24	1956 x 992 x 50	1950 x 986	23.5	300	36	8.06	45.5	8.56
Module		SPM30-12	SPM51-12	SPM81-12	SPM101-12	SPM131-12	SPM190-24	SPM300-24
Nominal Power (±3% tolerance)		30W	50W	80W	100W	130W	190W	300W
Cell type		Monocrystalline						
Number of cells in series		36					72	
Maximum system voltage (V)		1000V						
Temperature coefficient of P _{MPP} (%)		-0.48/°C	-0.48/°C	-0.48/°C	-0.48/°C	-0.48/°C	-0.48/°C	-0.48/°C
Temperature coefficient of V _{oc} (%)		-0.34/°C	-0.34/°C	-0.34/°C	-0.34/°C	-0.34/°C	-0.34/°C	-0.34/°C
Temperature coefficient of I _{sc} (%)		+0.037/°C	+0.037/°C	+0.037/°C	+0.037/°C	+0.05/°C	+0.037/°C	+0.037/°C
Temperature Range		-40°C to +85°C						
Surface Maximum Load Capacity		200kg/m ²						
Allowable Hail Load		23m/s, 7.53g						
Junction Box Type		PV-JH03-2	PV-JH02	PV-JH02	PV-JH02	PV-RH0301	PV-JH03	PV-JH200
Connector Type		MC4						
Length of Cables		450mm	750mm	900mm	900mm	900mm	900mm	1000mm
Output tolerance		+/-3%						
Frame		Aluminium						
Product warranty		2 years						
Warranty on electrical performance		10 years 90% + 25 years 80% of power output						
Smallest packaging unit		1 panel						
Quantity per pallet		40 panels	40 panels	20 panels	20 panels	20 panels	20 panels	20 panels

1) STC (Standard Test Conditions): 1000W/m², 25°C, AM (Air Mass) 1.5

BLUESOLAR POLYCRYSTALLINE PANELS



BlueSolar Polycrystalline 130W

- Low voltage-temperature coefficient enhances high-temperature operation.
- Exceptional low-light performance and high sensitivity to light across the entire solar spectrum.
- 25-year limited warranty on power output and performance.
- 2-year Limited warranty on materials and workmanship.
- Sealed, waterproof, multi-functional junction box gives high level of safety.
- High performance bypass diodes minimize the power drop caused by shade.
- Advanced EVA (Ethylene Vinyl Acetate) encapsulation system with triple-layer back sheet meets the most stringent safety requirements for high-voltage operation.
- A sturdy, anodized aluminum frame allows modules to be easily roof-mounted with a variety of standard mounting systems.
- Highest quality, high-transmission tempered glass provides enhanced stiffness and impact resistance.
- Pre wired quick-connect system with MC4 (PV-ST01) connectors.



MC4 connectors

Type	Module Size	Glass size	Weight	Electrical data under STC ⁽¹⁾					
				Nominal Power	Max-Power Voltage	Max-Power Current	Open-Circuit Voltage	Short-circuit Current	
				P _{MPP}	V _{MPP}	I _{MPP}	V _{oc}	I _{sc}	
Module	mm	mm	Kg	W	V	A	V	A	
SPP30-12	735x350x25	730x345	5.2	30	18	1.72	22.5	1.85	
SPP51-12	540x670x35	535x665	5.3	50	18	2.85	22.2	3.09	
SPP81-12	915x670x35	910x665	8	80	18	4.6	21.6	5.06	
SPP101-12	1005x670x35	1000x665	9	100	18	5.75	21.6	6.32	
SPP140-12	1480x670x35	1474x664	12.5	140	18	8.05	21.6	8.85	
SPP280-24	1956x992x50	1950x986	24	280	36	7.7	44.06	8.26	
Module	SPP30-12	SPP51-12	SPP81-12	SPP101-12	SPP140-12	SPP280-24			
Nominal Power (±3% tolerance)	30W	50W	80W	100W	140W	280W			
Cell type	Polycrystalline								
Number of cells in series	36						72		
Maximum system voltage (V)	1000V								
Temperature coefficient of P _{MPP} (%)	-0.47/°C	-0.48/°C	-0.48/°C	-0.48/°C	-0.48/°C	-0.47/°C			
Temperature coefficient of V _{oc} (%)	-0.34/°C	-0.34/°C	-0.34/°C	-0.34/°C	-0.35/°C	-0.34/°C			
Temperature coefficient of I _{sc} (%)	+0.045/°C	+0.037/°C	+0.037/°C	+0.037/°C	+0.037/°C	+0.045/°C			
Temperature Range	-40°C to +85°C								
Surface Maximum Load Capacity	200kg/m ²								
Allowable Hail Load	23m/s, 7.53g								
Junction Box Type	PV-JH03-2	PV-JH02	PV-JH02	PV-JH02	PV-JH02	PV-JH200			
Connector Type	MC4								
Length of Cables	450mm	750mm	900mm			1000mm			
Output tolerance	+/-3%								
Frame	Aluminium								
Product warranty	2 years								
Warranty on electrical performance	10 years 90% + 25 years 80% of power output								
Smallest packaging unit	1 panel								
Quantity per pallet	40 panels	40 panels	20 panels	20 panels	20 panels	20 panels			

1) STC (Standard Test Conditions): 1000W/m², 25°C, AM (Air Mass) 1.5

INVERTER/CHARGER SYSTEM WITH INTELLIGENT SHORE AND GENERATOR POWER MANAGEMENT

PowerControl: Dealing with limited generator or grid power All models in the MultiPlus range feature powerful battery chargers. When the largest model is working hard it can draw almost 10A from a 230V supply. Using the remote panel it is possible to 'dial-in' the maximum current that is available from mains or generator. The MultiPlus will then automatically regulate the charger taking account of other system AC loads and ensuring the charger only uses what is spare. This way it is possible to avoid tripping the mains power or overloading the generator.

POWER CONTROL ©

Battery charger reduces its output, if required, to avoid overload of supply when system consumption is high.

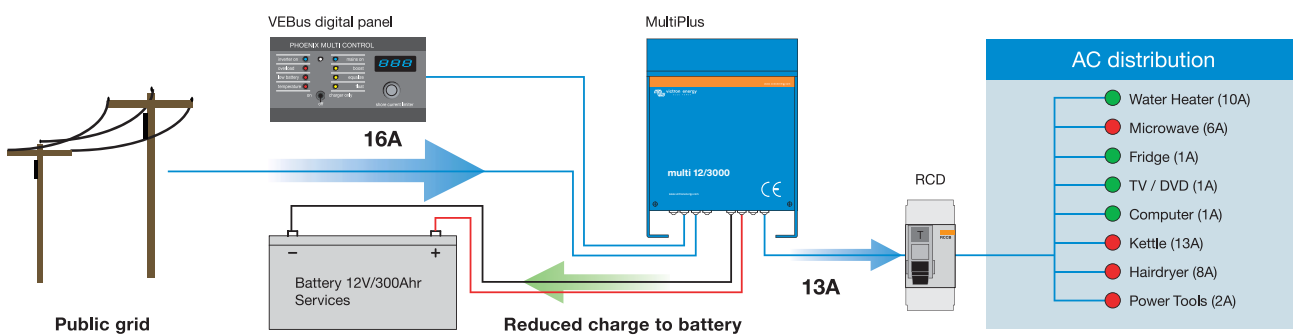

PowerAssist: Boosting the power available from mains or generator, an innovative feature of Multiplus. The feature that most distinguishes the MultiPlus from other inverter / chargers is PowerAssist. This feature takes the principle of PowerControl to a further dimension by allowing a MultiPlus to supplement the power available from mains or generator to 'assist' during periods of high demand. Peak power demand is almost always sustained only for short periods, either a few minutes (in the case of items like cooking appliances) or just a few seconds (in the case of the burst of energy needed to start an air-conditioning or refrigeration compressor).

With the capacity of the generator or mains power set on the remote panel, the MultiPlus detects when the load is becoming too much for the supply and will instantly provide the extra power required. When the demand has reduced, the unit returns to charging the battery. This feature is equally effective in large and small systems helping to reduce the required generator capacity or to achieve greater things with limited mains power. There is even a special feature to enable the MultiPlus/Quattro to work perfectly with portable generators.

POWER ASSIST ©

Inverter boosts incoming power, if required, to avoid overload of supply when system consumption exceeds supply.

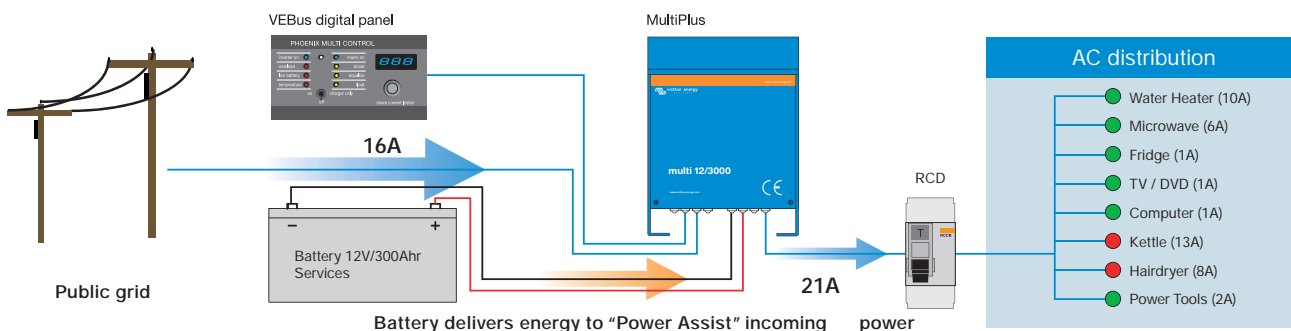

COMFORT SYSTEM

COMFORT PLUS SYSTEM

Appliance	System
Lighting	Quattro 12/3000/120
Communication & navigation	BMV602-S battery monitor
Water heater	2x12V/200AH and 1X80AH batteries
Microwave oven	Digital control remote panel
2 ring induction hob	Alternator 12/150
Coffee machine/Kettle	DC Link Box
TV/DVD	Isolation transformer
Laptop	Cyrix battery separator
Small chargers (mobile phone, electric shaver)	
Refrigerator and freezer	Solarpanel and MPPT Solar charger

Appliance	System
Lighting	2 x Quattro 24/5000/120
Communication & navigation	VE-NET Battery controller
Water heater	4x12V/200AH and 1X80AH batteries
Electric gallery with 4 ring induction hob, microwave/combi oven, refrigerator, freezer, washer/dryer.	Blue Power panel
Coffee machine and kettle	Alternator 12/150
TV/DVD	DC Link box
Multimedia PC	Isolation transformers
Small chargers (mobile, phone, shaver etc)	
Modest air-conditioning	Solarpanel and MPPT Solar charger

COMFORT SYSTEM - 7 KVA (30A) CAPACITY

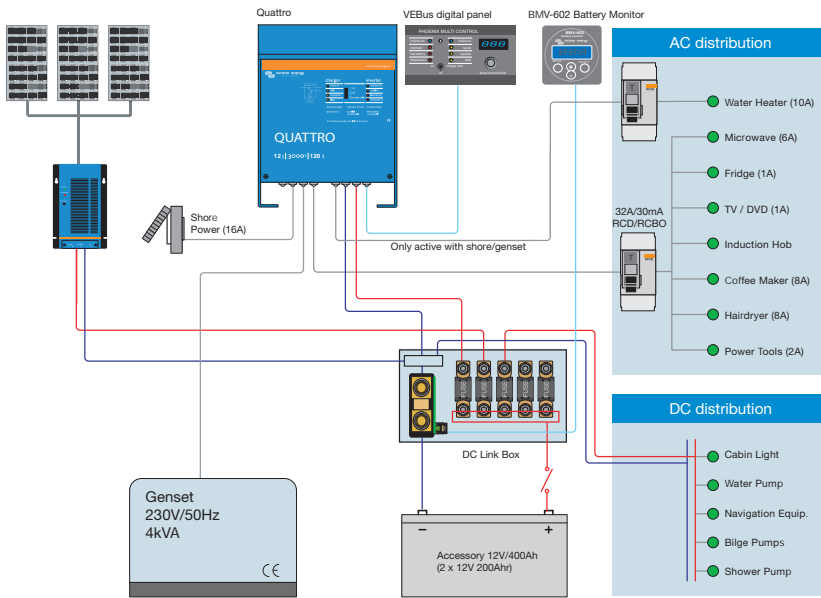

COMFORT PLUS SYSTEM - 25 KVA CAPACITY

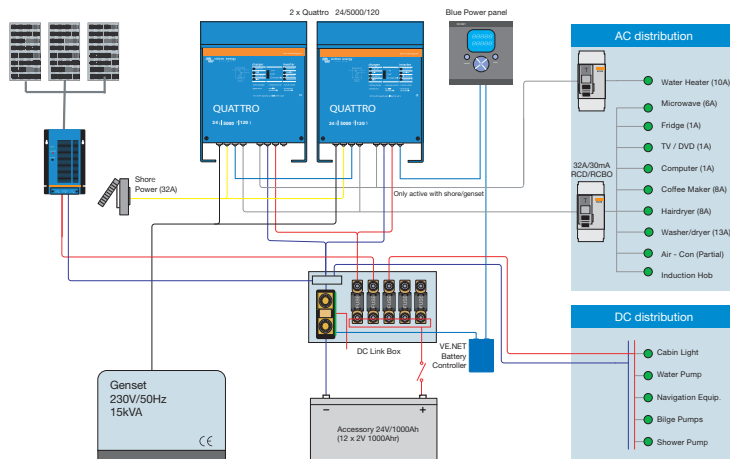

ABOUT VICTRON ENERGY

With over 39 years of experience, Victron Energy enjoys an unrivalled reputation for technical innovation, reliability and quality. Victron is a world leader in the supply of self-supporting electrical power. Our products have been designed to meet the most demanding situations faced by a diversity of craft, recreational and commercial alike. Victron's ability to meet the demand for customized off-grid systems is unprecedented. Our product range includes sine wave inverters and inverter/chargers, battery chargers, DC/DC converters, transfer switches, gel and AGM batteries, alternators, battery monitors, solar charge regulators, solar panels, complete network solutions and many other innovative solutions.

World-wide service and support

Having served the off-grid, industrial and vehicle markets as well as both the commercial and leisure marine sectors for over 39 years, Victron has an established network of dealers and distributors covering the whole world. Our customer base is such that providing prompt and competent local service is essential.

This is reflected in the capabilities of our support network. Our flexible approach to service support and our commitment to quick turnaround for repairs is marketleading. There are countless examples of Victron products that have provided for decades of reliable service in the most demanding applications. This level of reliability combined with the highest level of technical know-how results in Victron Energy power systems that offer the very best value available.



Photo: X-Yachts



ENERGY.
ANYTIME.
ANYWHERE.



Victron Energy B.V. / De Paal 35
1351 JG Almere / The Netherlands
Phone: +31 (0)36 535 97 00
Fax: +31 (0)36 535 97 40
e-mail: sales@victronenergy.com
www.victronenergy.com

SAL064136020
REV 12
2014-05